

Technical data



Available input voltages [Vdc]	12, 24 or 36
Available screw types	Acme or Ball
Max. static load at fully retracted [N]	
Acme screw models	11 350
Ball screw models	18 000
Min. / max. standard stroke [mm]	50 / 600
Duty cycle @ 25° C [%]	25
Temperature limits at operation [°C]	- 25 to + 65
Protection degree	IP65
Max. end play [mm]	1
Restraining torque [Nm]	–
Wire cross section [mm ²]	2
Wire length [mm]	165
Connector included	yes

Features

- Rugged and robust
- Aluminium cover tube with T-slot
- Position sensors can be fitted to the T-slots
- Trunnion mounting possible
- Anti rotation mechanism
- Weather resistant (IP65)
- Overload clutch (set to 1,2 – 1,5 × max. permissible load)
- Motor with auto reset thermal overload protection
- Acme or ball screw drive
- Holding brake prevents back driving on ball screw models
- Acme screw models are self-locking
- Safety nut on all ball screw models
- Can operate in a large temperature range
- Accepts large input voltage variations
- Maintenance free

Options

- Potentiometer feedback
- Hand wind
- Custom RAL color

Performance table

Model	Max. dynamic load [N]	Speed @ min. load [mm/s]	Speed @ max. load [mm/s]
DA12-05A5	1100	54	32
DA24-05A5	1100	54	32
DA12-05B5	2250	61	37
DA24-05B5	2250	61	37
DA12-10A5	2250	30	18
DA24-10A5	2250	30	18
DA12-10B5	4500	30	19
DA24-10B5	4500	30	19
DA12-20A5	2250	15	12
DA24-20A5	2250	15	12
DA12-20B5	4500	15	12
DA24-20B5	4500	15	12
DA12-21B5	6800	15	11
DA24-21B5	6800	15	11

Standard strokes

Ordering stroke [cm]	Actual stroke S [mm]
5	50
10	100
15	150
20	200
25	250
30	300
35	350
40	400
45	450
50	500
55	550
60	600

Dimensions

Acme screw driven models

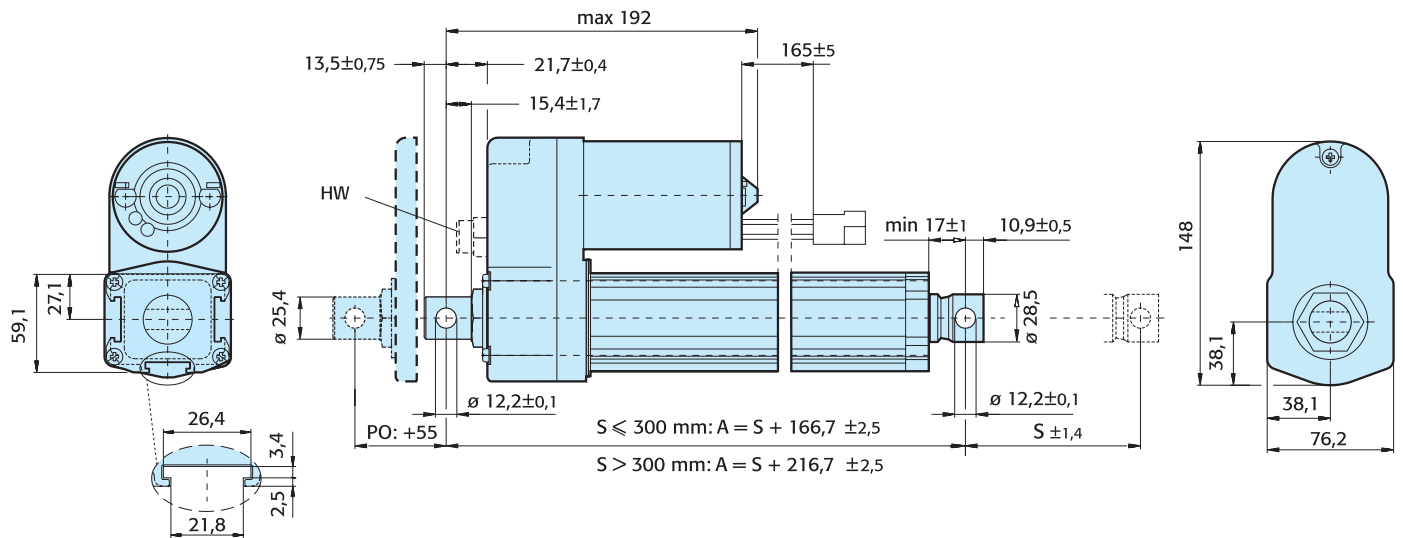

Ball screw driven models

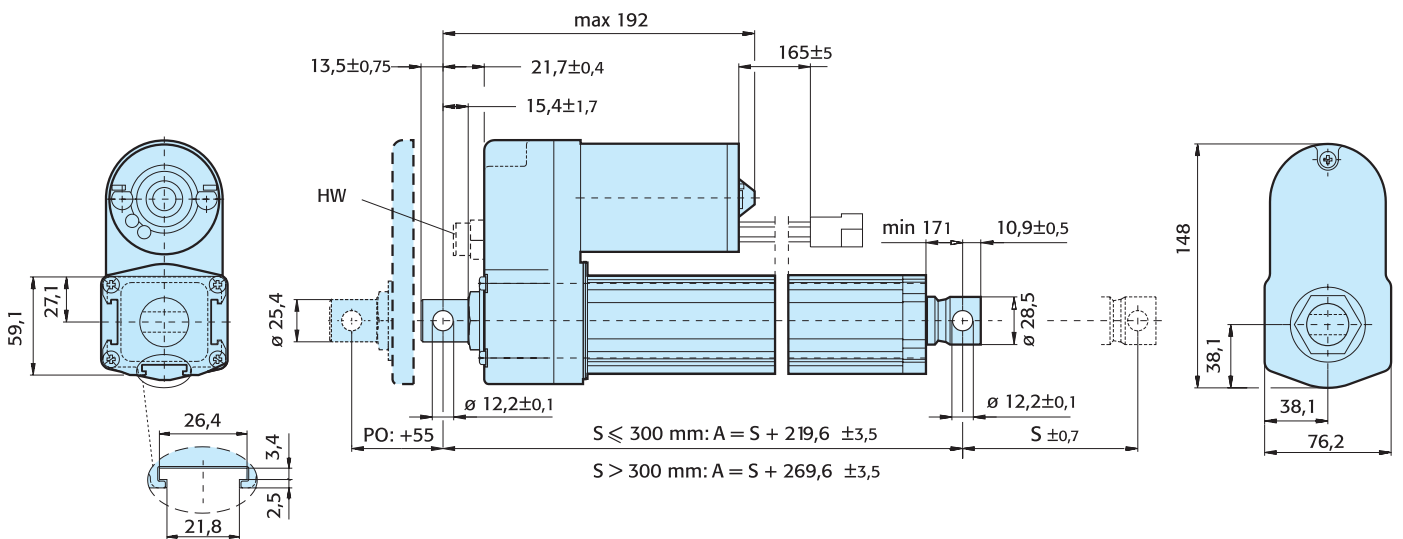

Performance diagrams

