

# Automation Components

**New!**

**T130 industrial actuator –  
built for 100% heavy  
duty operation**



- Strong
- Robust
- High accuracy
- 100% duty cycle
- Speed up to 2 m/s
- Load up to 40000 N
- Accessories such as mounting kits, magnet sensors, flanges and gears available.

GB

***Industrial  
Actuator  
T130***

Solutions by **DanaherMotion**

**THOMSON TOLLO™**

[www.DanaherMotion.com](http://www.DanaherMotion.com)

## Technical data

	T130	T130	T130
Designation	T13-B4010M***	T13-B4020M***	T13-B4040M***
Max. stroke [m]	2	2	2
Max. speed [m/s]	0,4	1	2
Max. input speed [rpm]	2500	3000	3000
Temperature range [°C]	-20 – +70	-20 – +70	-20 – +70
Weight (L in m) [kg]	18,5 + (30 × (L - 0,293))	18,5 + (30 × (L - 0,293))	18,5 + (30 × (L - 0,293))
Max. dynamic load Fx [N]	40000	35000	15000
Max. static load Fx [N]	45000	45000	45000
Max. load Fr [N]	800	800	800
Max. torque Ma [Nm]	300	300	300
Max. torque Mta [Nm]	140	140	140
Max. force Frd [N]	2000	2000	2000
Screw diameter [mm]	40	40	40
Screw lead [mm/revolution]	10	20	40
Repeatability [± mm]	0,05	0,05	0,05
Resolution [mm]	0,1	0,1	0,1

## Dimensions

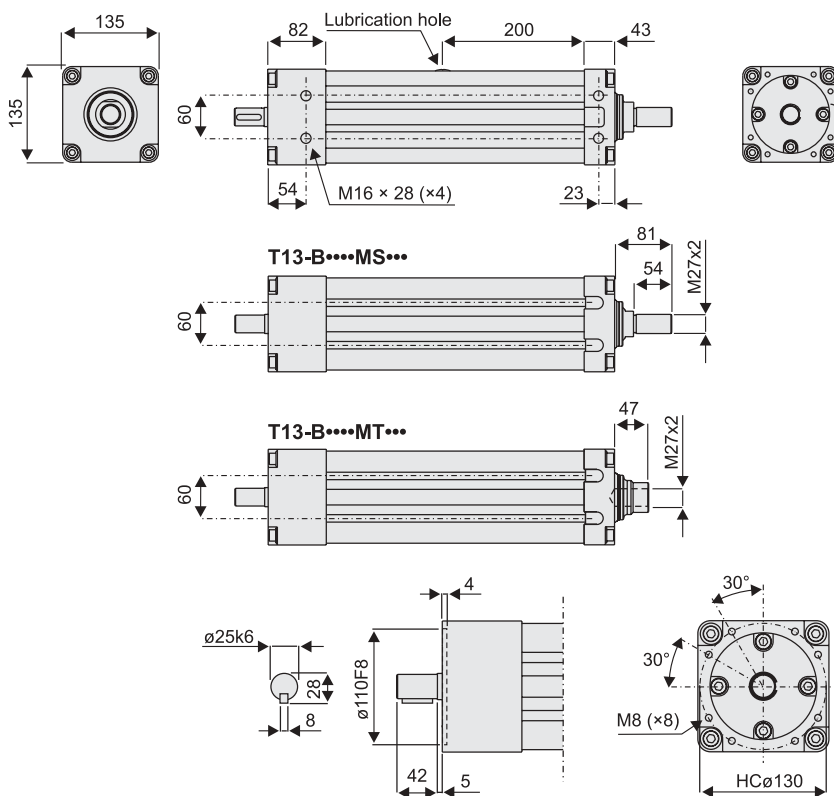

## Forces

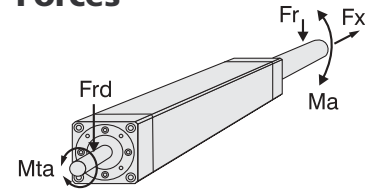

## Ordering length in millimetres

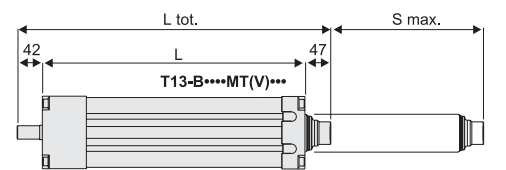
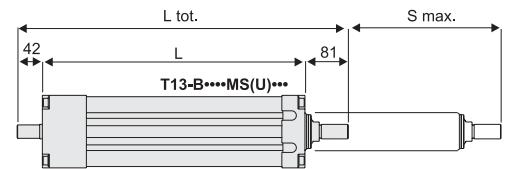

Designation	Total length	Length to order
T13-B***MS(U)***	L tot. = L + 123	L = S max. + 293
T13-B***MT(V)***	L tot. = L + 89	L = S max. + 293

## Ordering key

Key example: T 13 - B 4020 M S 450

Unit type	T	T-serie actuator
Size	13	130
Hyphen	-	
Drive type	B	Ball screw and ball nut
Screw diameter / lead	4010	40 mm / 10 mm
	4020	40 mm / 20 mm
	4040	40 mm / 40 mm
Engineering unit	M	Metric
Adapter type	S T U V	M27x2 outside thread M27x2 inside thread M33x2 outside thread M33x2 inside thread
Ordering length in cm (L)	...	

Tollo Linear AB, Box 9053, SE-291 09 Kristianstad, Sweden, Tel. +46 (0)44 24 67 00, Fax. +46 (0)44 24 40 85, E-mail: helpdesk@tollo.com

Solutions by **DanaherMotion**

**THOMSON TOLLO**

www.DanaherMotion.com

DW110485gb-0309

Tollo Linear AB © 2003 Printed in Sweden