

Automation Components

T90 industrial actuator – the small and robust heavy duty actuator



- Small
- Strong
- Robust
- High accuracy
- 100% duty cycle
- Speed up to 1,25 m/s
- Load up to 10000 N
- Accessories such as mounting kits, magnet sensors, flanges and gears available.

GB

**Industrial
Actuator
T90**

Solutions by **DanaherMotion**

THOMSON TOLLO™

www.DanaherMotion.com

Technical data

	T90	T90
Designation	T09-B2510M...	T09-B2525M...
Max. stroke [m]	1,5	1,5
Max. speed [m/s]	0,5	1,25
Max. input speed [rpm]	3000	3000
Temperature range [°C]	-20 – +70	-20 – +70
Weight (L in m) [kg]	4 + 16,2 × L	4 + 16,2 × L
Weight extension tube [kg]	5,5 × L	5,5 × L
Max. dynamic load Fx [N]	10000	10000
Max. load Fr [N]	60	60
Max. torque Mta [Nm]	35	35
Max. force Frd [N]	800	800
Screw diameter [mm]	25	25
Screw lead [mm/revolution]	10	25
Repeatability [± mm]	0,05	0,05
Resolution [mm]	0,1	0,1

Forces

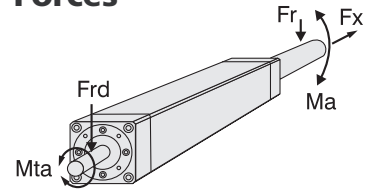

Ordering key

Key example: **T 09 - B 2525 M 450**

Unit type T-series actuator	T
Size 90	09
Hyphen	-
Drive type Ball screw and ball nut	B
Screw diameter / lead 25 mm / 10 mm 25 mm / 25 mm	2510 2525
Engineering unit Metric	M
Ordering length in cm (L)	450

Dimensions

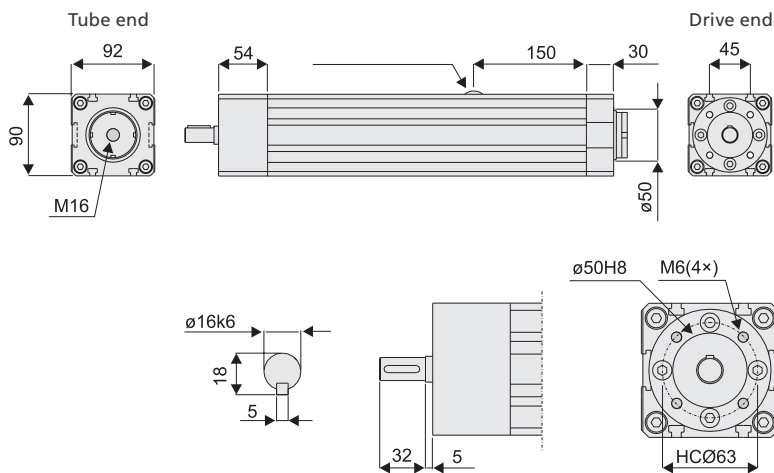

Ordering length in millimetres

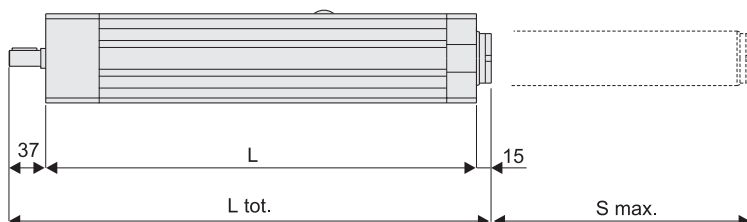

Designation	Total length	Length to order
T09-B...M...	L tot. = L + 52	L = S max. + 195

Tollo Linear AB, Box 9053, SE-291 09 Kristianstad, Sweden, Tel. +46 (0)44 24 67 00, Fax. +46 (0)44 24 40 85, E-mail: helpdesk@tollo.com

Solutions by **DanaherMotion**

THOMSON TOLLO

www.DanaherMotion.com

DW110492gb-0312
Tollo Linear AB © 2003 Printed in Sweden