

# INDUSTRIAL LINEAR ACTUATORS

JUNE-2005

[www.DanaherMotion.com](http://www.DanaherMotion.com)



**THOMSON™**

**DANAHER**  
MOTION  
*Solutions by*

**GB**

# Mechanical and Electro-Mechanical Product Solutions by Danaher Motion

## New Name, Established Brands

Danaher Motion's wide range of motion control systems and components offer customers an unprecedented choice in selecting the right solution to match their particular application requirements. Our product innovations have been improving the efficiency and productivity of complex manufacturing operations for over 60 years through trusted brand names such as Dover, Kollmorgen, Pacific Scientific, Portescap and Thomson in industries as diverse as semiconductor, aerospace and defence, mobile-off-highway, packaging, medical and robotics.

In addition, Danaher Motion, through Motion Engineering (MEI), offers powerful integrated motion control solutions with its industry-leading, multi-axis motion platforms and SynqNet™ communications network for ultra-reliable machine performance. From software and controller, through the communications network to drives and I/O devices, to mechanical and electro-mechanical products, Danaher Motion differentiates itself in the marketplace by designing standard and custom solutions to satisfy the most demanding application requirements.

Our growing family of leading motion control products and application expertise tells only half the story. With a worldwide service and support infrastructure, our field service engineers and support teams are available to assist whenever they are needed. It is part of Danaher Corporation's unrelenting focus on its customer. That's why more and more design engineers are turning to Danaher Motion to meet their motion control requirements.

### Danaher Motion Values

- Application Expertise
- Broad & Innovative Motion Control Products and Systems
- Customer Focus
- Customisable Products and Services
- Motion Control Pioneers with Global Staying Power
- Operational Excellence



**KOLLMORGEN**



**Portescap**

**THOMSON**





## Rugged and reliable

Thomson Tollo linear actuators incorporate strong, high quality components that has been proven under the hardest operation conditions to ensure a long and trouble free operation.

Rugged spur gearings, aircraft quality lubricants, non corrosive extension tube and high performance motors with built in thermal protection maximum the life and value for the user.

## Linear actuator advantages

A Thomson Tollo actuator with 100 mm stroke can provide 6800 N of force from a 300 mm long package. This means that pneumatic and hydraulic cylinders easily can be replaced thus saving energy, space and power sources while making control easier and accurate positioning possible.

The actuators will operate equally well if pulling or pushing the load. They hold a load indefinitely without power and can be equipped with position feedback devices, limit switches and other optional functions and features.

## Broad range of models

The broad range of models makes it easy to choose the perfect actuator for your application. We can offer an actuator whether it should be small, fast, quiet, strong, wheater protected or light weight. And if you can not find anything that fits among our standard range we are happy to customize an actuator to your needs.

## Typical applications

Applications areas where linear actuators are used includes:

- Mobile-off-Highway equipment (harvesters, tractors, trucks, bailers, forestry vehicles, trains, construction equipment, boats, etc.)
- Health and fitness equipment (x-ray equipment, wheel chairs, handicap adaption of cars, gym equipment, dental chairs, patient lifts, etc.)
- In ventilation and valve control
- In the operation of windows, gates, doors and hatches
- In all type of industrial equipment where linear motion is a need.

## Actuators

Actuator model	Max. load [N]	Max. stroke [mm]	Max. speed [mm/s]	Available supply voltages		Available screw types			Overload clutch		End of stroke limit switches		Anti rotation mechanism	
				[Vdc]	[Vac]	Acme	Ball	Worm	Yes	No	Yes	No	Yes	No
Electrak LA1-S	500	150	75	12, 24, 36		x				x	x			x
Electrak LA1-SP	500	150	75	12, 24, 36		x				x		x	x	
Electrak LA10	6800	600	60	12, 24, 36		x	x		x			x		x
Electrak LA14	6800	600	60	12, 24, 36		x	x		x			x	x	
Electrak LA5	6800	600	60		230, 400	x	x		x			x		x
Electrak LA24	6800	600	60		230, 400	x	x		x			x	x	
Electrak FA14	6800	600	60	no motor	no motor	x	x		x			x	x	
Electrak PPA-AC	6670	914	33		110, 230		x		x		x*			x
Electrak PPA-DC	6670	914	15	12, 24, 36			x		x		x*			x
Electrak PPA-M	6670	914	8,3	no motor	no motor		x			x		x		x
Electrak E050	510	200	48	12, 24, 36				x	x		x*		x	
Electrak Q050	510	200	38	12, 24, 36				x	x		x*		x	
Electrak E150	2000	400	71	12, 24, 36				x		x	x*		x	
Movoact-AC	6800	600	60		230, 400	x	x		x			x	x	
Movoact-DC	6800	600	60	12, 24, 36		x	x		x			x	x	
LoadMaster 80	2000	1500	110	12, 24		x	x			x		x		not applicable

\* optional

## Controls

Control model	Part number	Suitable actuators	Input voltage		Output voltage [Vdc]	Number of outputs	Max. output current [A]	Duty cycle @ 20° C [%]	Electronic limit switches	Limit switch inputs
			[Vac]	[Vdc]						
AC-020	DCB21-1S3	LA1	230	–	24	1	3	10	yes	no
AC-020	DCB24-2S33	LA1	230	–	24	2	3	10	yes	no
AC-050	DCE24-1E	E050, Q050	230	–	24	1	2,5	10	yes	no
AC-050	DCE24-2E	E050, Q050	230	–	24	2	2,5	10	yes	no
AC-150	DCF24-1F	E150, LoadMaster 80	230	–	24	1	8	10	yes	no
AC-150	DCF* nicht	E150, LoadMaster 80	230	–	24	2	8	10	yes	no
AC-063B	DCA24-1B	LA14	–	12 – 36	12 – 36	1	30 – 12	10	no	yes
AC-063B	DC24-1B	LA10, PPA-DC, Movoact	–	12 – 36	12 – 36	1	30 – 12	10	no	no
AC-063C	DCA24-1C	LA14	230	–	24	1	17	10	no	yes
AC-063C	DC24-1C	LA10, PPA-DC, Movoact	230	–	24	1	17	10	no	no
AC-247ELS	D604 110	LA1, E050, Q050, E150, LoadMaster 80	–	12 – 24	12 – 24	1	10 – 5	10	yes	no
AC-247ELS	D604 111	LA1, E050, Q050, E150, LoadMaster 80	–	12	12	1	12	10	yes	no
AC-247ELS	D604 112	LA1, E050, Q050, E150, LoadMaster 80	–	24	24	1	8	10	yes	no

## Electrak LA series

- Strong, rugged and reliable
- Ball screw or acme screw drive
- DC or AC power supply
- Stroke up to 600 mm
- Speed from 12 to 75 mm/s
- Load up to 6800 N



**PAGE 7**

## Electrak PPA series

- Robust and versatile
- Ball screw drive
- DC or AC power supply
- Stroke up to 914 mm
- Speed from 5 to 28 mm/s
- Load up to 6670 N

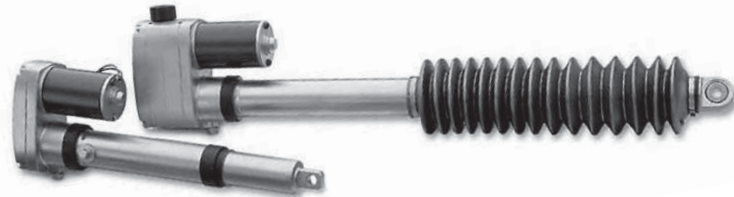

**PAGE 29**

## Electrak E series

- Lightweight, low noise and space saving
- Low cost
- Stroke up to 400 mm
- Speed up to 70 mm/s
- Load up to 2000 N
- Non corrosive

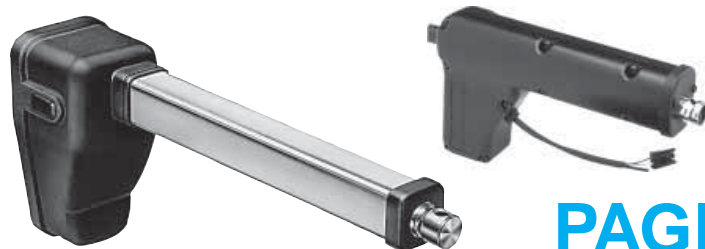

**PAGE 39**

## Movoact

- Self supporting lifting column with extruded aluminium housing
- Ball screw or acme screw drive
- DC or AC power supply
- Stroke up to 600 mm
- Speed from 12 to 60 mm/s
- Load up to 6800 N



**PAGE 47**

## LoadMaster 80

- Rodless actuator for horizontal or vertical use
- Quiet operation for indoor domestic or medical applications
- Trapezoidal or ball screw drive
- Stroke up to 1500 mm
- Speed up to 110 mm/s
- Load up to 2000 N

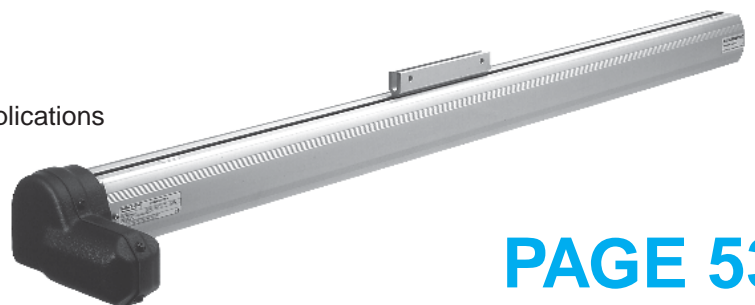

**PAGE 53**

## Controls

- Controls available for all actuator models
- Models for AC or DC power supply
- Versions with limit switch inputs
- Versions with electronic limit switches (ELS)
- Models with outputs for one or two actuators
- Hand controls available for some models



**PAGE 59**



## Basic actuator design

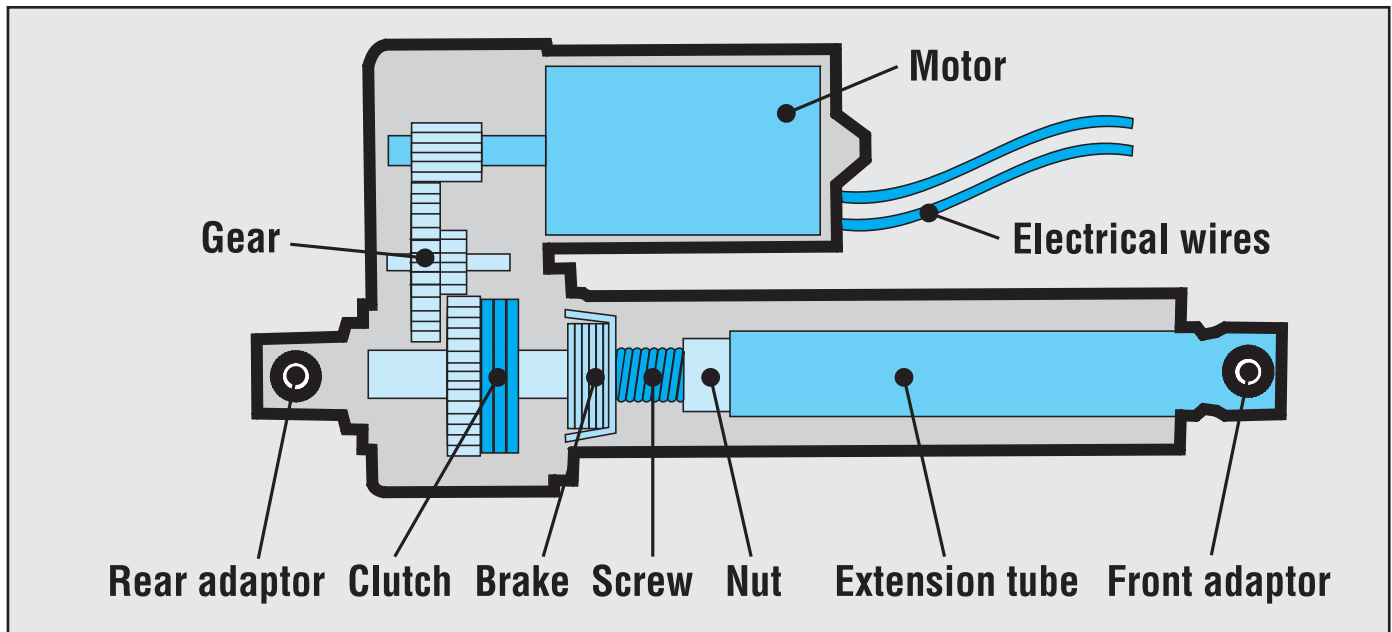

## Technology overview

### Anti coast brake

Ball screw actuators with an AC motor can, depending of the load, overrun before it comes to a complete stand still after the power is being switched off. This overrun is eliminated by the anti coast brake option.

### Anti rotation mechanism

The anti rotation mechanism prevents the extension tube from rotating at the end of stroke thus eliminating the restraining torque.

### Duty cycle

The duty cycle is the allowed time in percent of the total time that the actuator may be working at the maximum rated load at a specified temperature. Example: a duty cycle of 25 % at 25° C means that a unit that runs for 10 second must be off for 30 seconds ( $10 / (10+30) = 25\%$ ) if the temperature is 25° C and it runs at max. rated load. The duty cycle may be higher if the temperature is lower or/and the load is less than maximum.

### ELS - Electronic Limit Switches

ELS which stands for Electronic Limit Switches and is a current sensing function used in some actuator control models. The function sense the current and if the current exceeds a pre-set level in any direction the control cuts the power to the motor in that particular direction. This function can be used to detect and stop at the ends of the actuator stroke or to stop the actuator if it runs into an obstacle.

### IP code

The IP code describe how well the actuator is protected from objects and water.

IP33: protected against the penetration of solid objects having a diameter greater than 2,5 mm and from rain at an angle up to 60°.

IP44: protected against the penetration of solid objects having a diameter greater than 1 mm and from splashing water in all directions.

IP45: protected against the penetration of solid objects having a diameter greater than 1 mm and from water jets in all directions.

IP51: protected from dust and vertical dripping water (condensation).

IP56: protected from dust and jets of water and waves in all directions.

IP65: dust tight and protected against water jets in all directions.

### Limit switches

There are two types of limit switches. The "end of stroke limit switches" stops the motion at the end of the stroke while the "adjustable limit switches" can be set to stop the motion at any desired position along the stroke.

### Maximum operation time

The maximum operation time is the max. time that the actuator may work before it must stand still with the power switched off. If the duty cycle is 25 % and the max. operation time is 45 seconds then the actuator may run for 45 seconds before it must stand still for 180 seconds.

### Position feedback option

The position feedback can either be obtained by a potentiometer or a hall effect sensor. In the first case a potentiometer in the actuator linearly changes resistance in accordance with the position of the extension tube. In the second case a hall effect sensor generates a pulse every 0,84 mm of extension tube travel. In both cases the resistance/pulses are measured/counted by a customer supplied control.

### Restraining torque

Restraining torque is the torque that the load and the holding brackets must withstand so that the extension tube moves instead of rotate. Actuators with "anti rotation mechanism" do not have any restraining torque as they are restrained internally.

### Spline safety function

The spline safety function is an optional safety function on LoadMaster 80 that will stop downwards motion in case the carriage (the moving member) collides with an obstacle. The motor will keep running but the carriage will stand still. When reversing the motor rotation the carriage will automatically start to move upwards again.

## Elektrak LA1-S

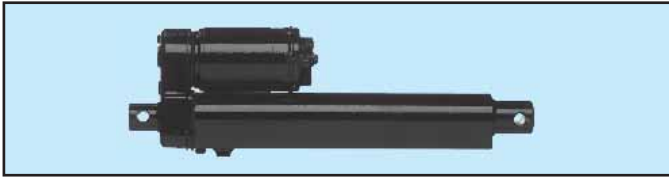

- IP65
- 12, 24 or 36 Vdc power supply
- Stroke from 25 to 150 mm
- End of stroke limit switches
- Self locking acme screw

## Elektrak LA1-SP



- IP65
- 12, 24 or 36 Vdc power supply
- Stroke from 50 to 150 mm
- Potentiometer feedback (no limit switches)
- Self locking acme screw and anti rotation mechanism

## Electrak LA10

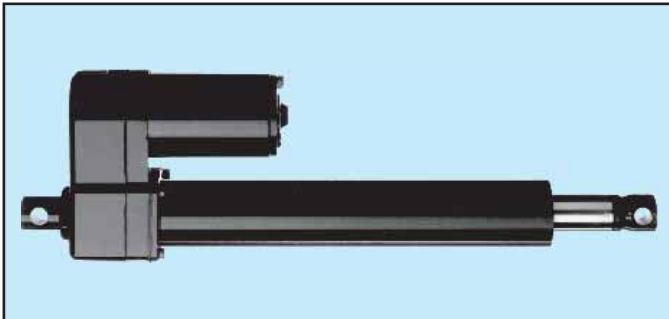

- IP65
- 12, 24 or 36 Vdc power supply
- Standard stroke up to 600 mm
- Ball or acme screw
- Custom RAL color possible.

## Electrak LA14

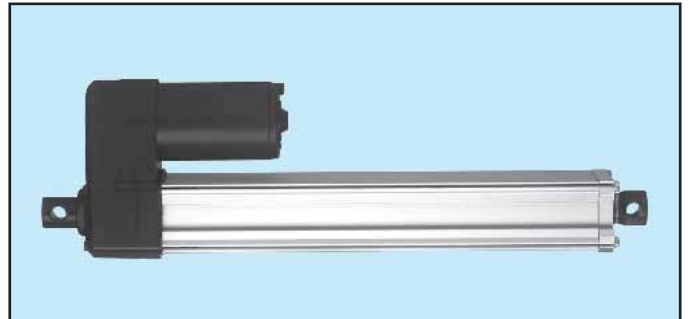

- IP65
- 12, 24 or 36 Vdc power supply
- Standard stroke up to 600 mm
- Ball or acme screw
- Anti rotation mechanism
- Aluminium cover tube with T-slot.

## Electrak LA5



- IP45
- 1 x 230 Vac or 3 x 400 Vac power supply
- Standard stroke up to 600 mm
- Ball or acme screw
- Custom RAL color possible.

## Electrak LA24



- IP45
- 1 x 230 Vac or 3 x 400 Vac power supply
- Standard stroke up to 600 mm
- Ball or acme screw
- Anti rotation mechanism
- Aluminium cover tube with T-slot
- Version without motor available (ElectrakFA14).

## Technical data



Available input voltages [Vdc]	12, 24 or 36
Available screw types	Acme
Max. static load at fully retracted [N]	1300
Min. / max. standard stroke [inch]	
S-model	1 / 6
SP-model	2 / 6
Duty cycle @ 25° C [%]	25
Temperature limits at operation [°C]	- 25 to + 65
Protection degree	IP65
Max. end play [mm]	0,9
Restraining torque [Nm]	
S-model	2,3
SP-model	-
Wire cross section [mm <sup>2</sup> ]	1
Wire length [mm]	100
Connector included	yes

## Features for both LA1-S and LA1-SP

- Small
- Weather resistant (IP65)
- Withstand 96 hour salt spray test
- Motor with auto reset thermal overload protection
- Self locking acme screw
- Can operate in a large temperature range
- Accepts large input voltage variations
- Maintenance free
- Models with higher load capacity possible on demand

## Features for LA1-S

- End of stroke limit switches
- Six standard strokes

## Features for LA1-SP

- Potentiometer feedback
- Anti rotation mechanism
- Three standard strokes

## Options

- Custom RAL color

## Engineering notes

- No clutch

## Performance table

Model	Max. dynamic load [N]	Speed @ min. load [mm/s]	Speed @ max. load [mm/s]
S(P)12-09A04	110	75	52
S(P)24-09A04	110	75	52
S(P)12-09A08	225	45	33
S(P)24-09A08	225	45	33
S(P)12-17A08	340	26	17
S(P)24-17A08	340	26	17
S(P)12-17A16	340	14	7
S(P)24-17A16	340	14	7

## Standard strokes

LA1-S ordering stroke	Actual stroke S [mm]
01	21
02	46
03	72
04	97
05	122
06	148

LA1-SP ordering stroke	Actual stroke S [mm]
02	59
04	115
06*	171

\* not possible with gear ratio 16:1



## Dimensions

### LA1-S

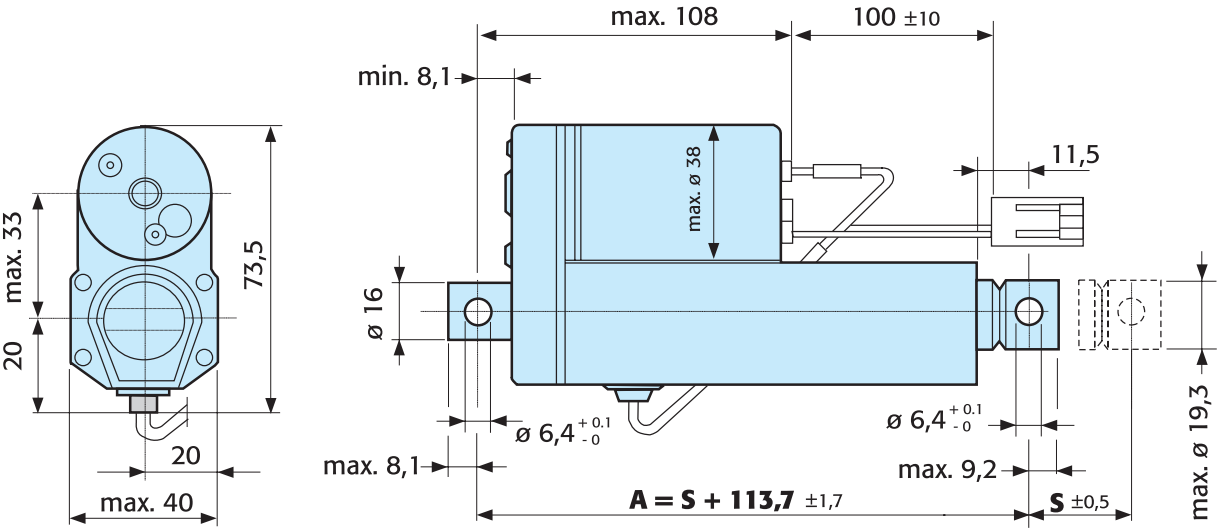

### LA-SP

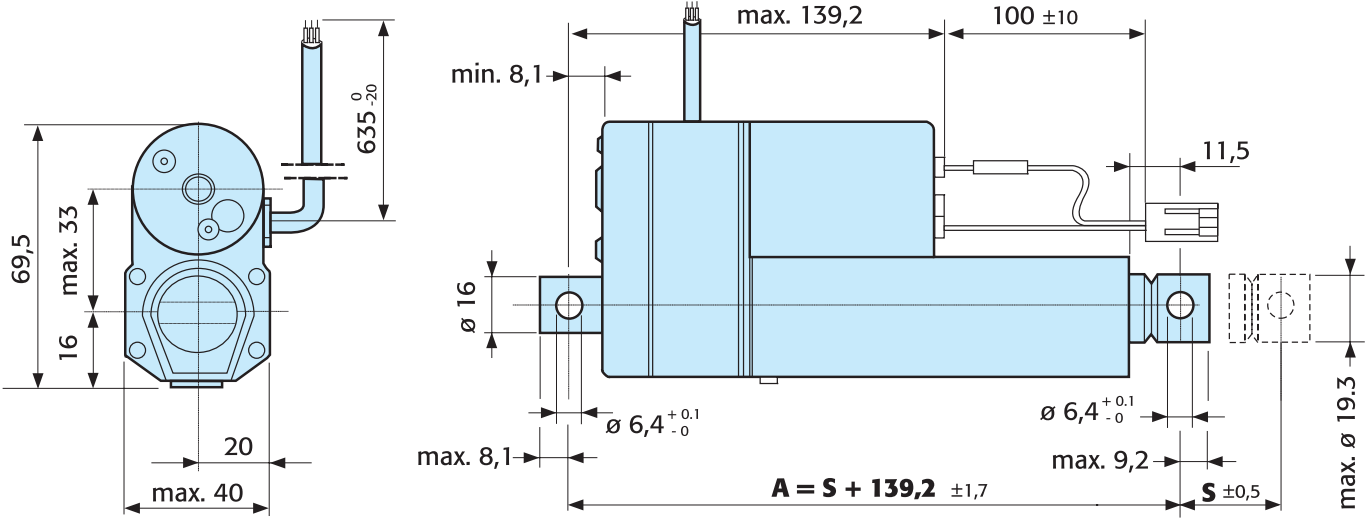

## Performance diagrams

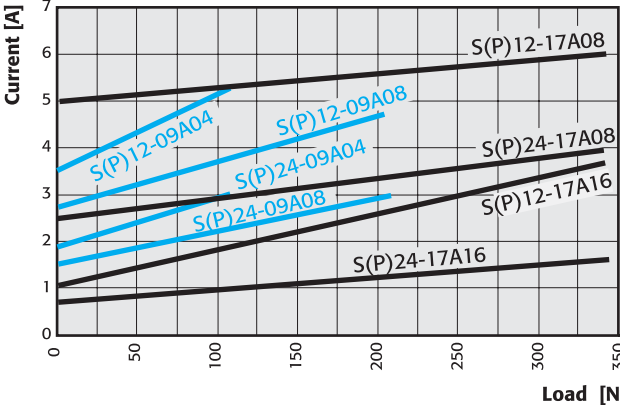
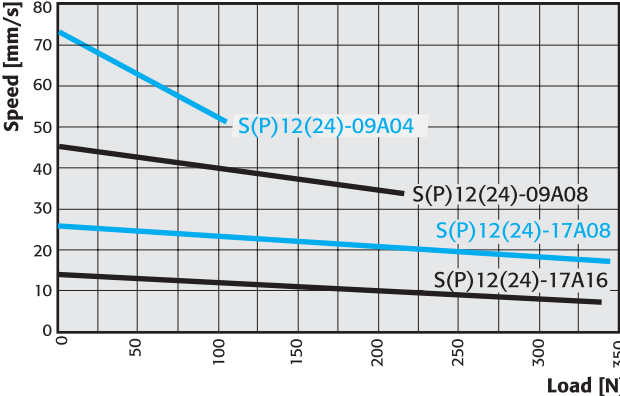

## Technical data



Available input voltages [Vdc]	12, 24 or 36
Available screw types	Acme or Ball
Max. static load at fully retracted [N]	
Acme screw models	11 350
Ball screw models	18 000
Min. / max. standard stroke [inch]	4 / 24
Duty cycle @ 25° C [%]	25
Temperature limits at operation [°C]	- 25 to + 65
Protection degree	IP65
Max. end play [mm]	1
Restraining torque [Nm]	11,3
Wire cross section [mm <sup>2</sup> ]	2
Wire length [mm]	165
Connector included	yes

## Features

- Rugged and robust
- Weather resistant (IP65)
- Withstand 96 hour salt spray test
- Overload clutch (set to 1,2 – 1,5 × max. permissible load)
- Motor with auto reset thermal overload protection
- Acme or ball screw drive
- Holding brake prevents back driving on ball screw models
- Acme screw models are self-locking
- Safety nut on all ball screw models
- Can operate in a large temperature range
- Accepts large input voltage variations
- Maintenance free

## Options

- Potentiometer feedback
- Hand wind
- Custom RAL color

## Performance table

Model	Max. dynamic load [N]	Speed @ min. load [mm/s]	Speed @ max. load [mm/s]
D12-05A5	1100	54	32
D24-05A5	1100	54	32
D12-05B5	2250	61	37
D24-05B5	2250	61	37
D12-10A5	2250	30	18
D24-10A5	2250	30	18
D12-10B5	4500	30	19
D24-10B5	4500	30	19
D12-20A5	2250	15	12
D24-20A5	2250	15	12
D12-20B5	4500	15	12
D24-20B5	4500	15	12
D12-21B5	6800	15	11
D24-21B5	6800	15	11

## Standard strokes

Ordering stroke [inch]	Actual stroke S [mm]
4	102
6	152
8	203
10	254
12	305
14	356
16	406
18	457
20	508
24	610



## Technical data



Available input voltages [Vdc]	12, 24 or 36
Available screw types	Acme or Ball
Max. static load at fully retracted [N]	
Acme screw models	11 350
Ball screw models	18 000
Min. / max. standard stroke [mm]	50 / 600
Duty cycle @ 25° C [%]	25
Temperature limits at operation [°C]	- 25 to + 65
Protection degree	IP65
Max. end play [mm]	1
Restraining torque [Nm]	–
Wire cross section [mm <sup>2</sup> ]	2
Wire length [mm]	165
Connector included	yes

## Features

- Rugged and robust
- Aluminium cover tube with T-slot
- Position sensors can be fitted to the T-slots
- Trunnion mounting possible
- Anti rotation mechanism
- Weather resistant (IP65)
- Overload clutch (set to 1,2 – 1,5 × max. permissible load)
- Motor with auto reset thermal overload protection
- Acme or ball screw drive
- Holding brake prevents back driving on ball screw models
- Acme screw models are self-locking
- Safety nut on all ball screw models
- Can operate in a large temperature range
- Accepts large input voltage variations
- Maintenance free

## Options

- Potentiometer feedback
- Hand wind
- Custom RAL color

## Performance table

Model	Max. dynamic load [N]	Speed @ min. load [mm/s]	Speed @ max. load [mm/s]
DA12-05A65	1100	54	32
DA24-05A65	1100	54	32
DA12-05B65	2250	61	37
DA24-05B65	2250	61	37
DA12-10A65	2250	30	18
DA24-10A65	2250	30	18
DA12-10B65	4500	30	19
DA24-10B65	4500	30	19
DA12-20A65	2250	15	12
DA24-20A65	2250	15	12
DA12-20B65	4500	15	12
DA24-20B65	4500	15	12
DA12-21B65	6800	15	11
DA24-21B65	6800	15	11

## Standard strokes

Ordering stroke [cm]	Actual stroke S [mm]
5	50
10	100
15	150
20	200
25	250
30	300
35	350
40	400
45	450
50	500
55	550
60	600



## Dimensions

### Acme screw driven models

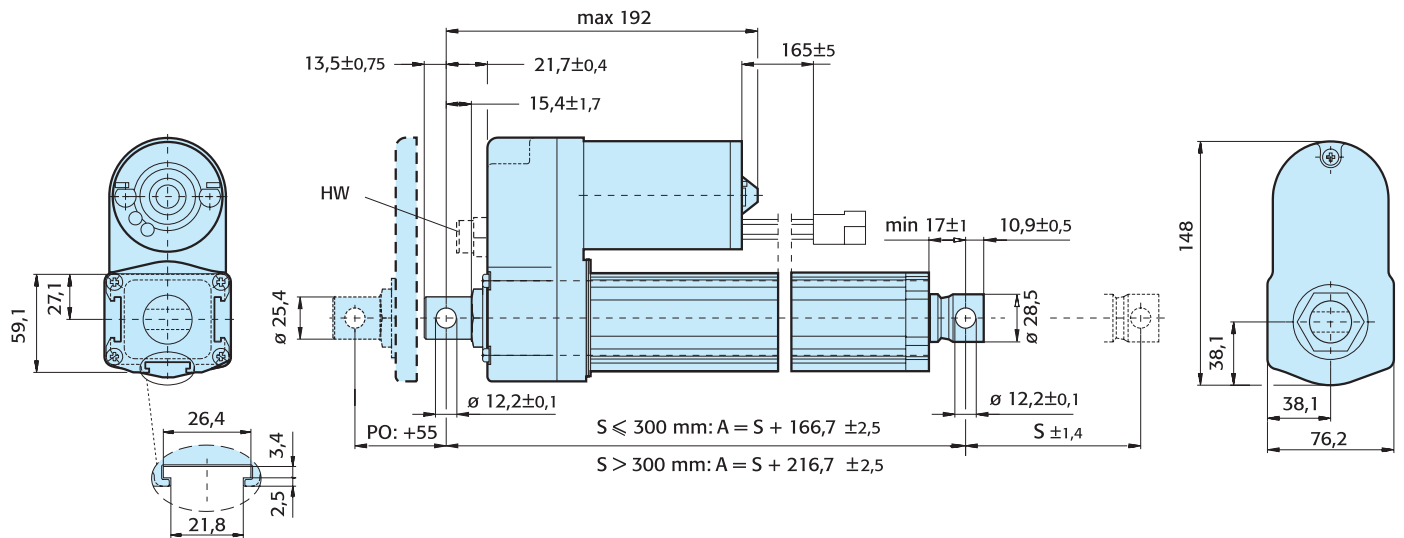

### Ball screw driven models

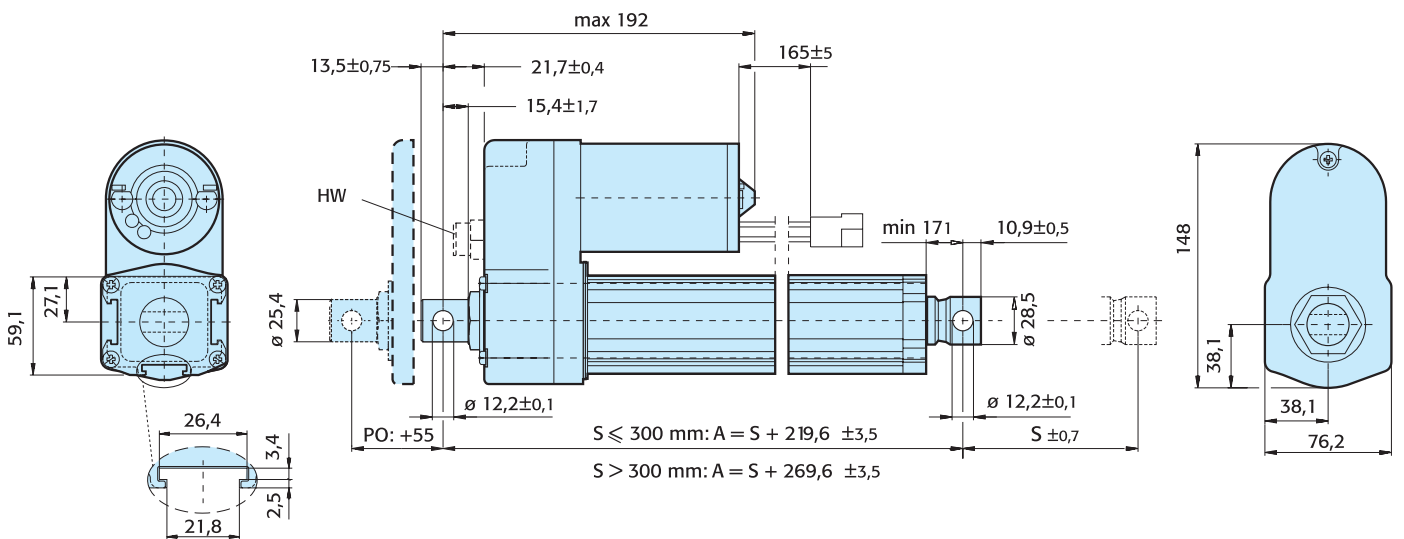

## Performance diagrams

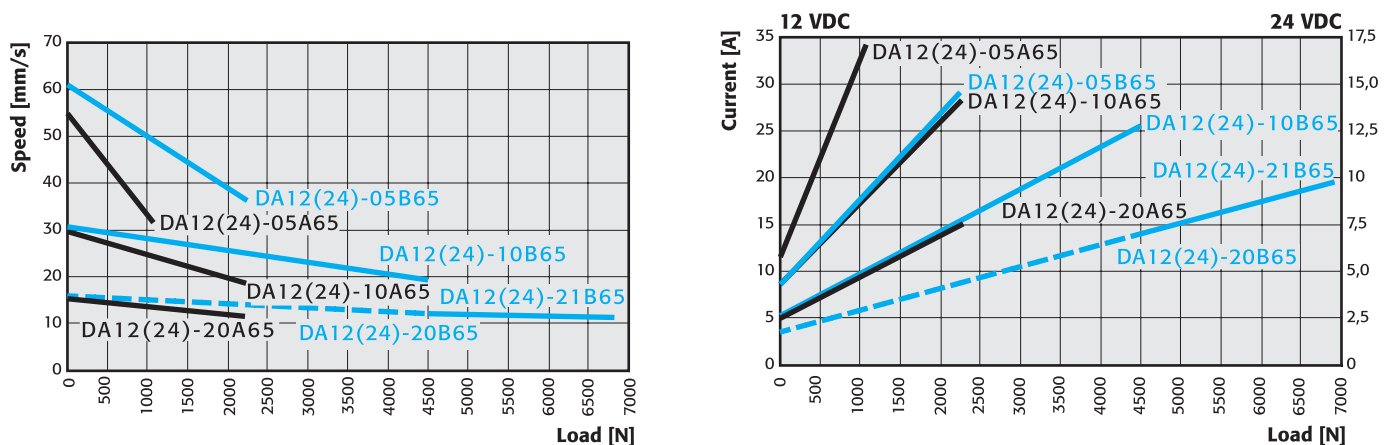

## Technical data



Available input voltages [Vac]	1 × 230 or 3 × 400
Input frequency [Hz]	50
Available screw types	Acme or Ball
Max. static load at fully retracted [N]	
Acme screw models	11 350
Ball screw models	18 000
Min. / max. standard stroke [inch]	4 / 24
Duty cycle @ 25° C [%]	25
Max. operation time [s]	45
Temperature limits at operation [°C]	- 25 to + 65
Protection degree	IP45
Max. end play [mm]	1
Restraining torque [Nm]	12
Wire cross section [mm <sup>2</sup> ]	1,5
Wire length [mm]	600
Connector included	no

## Features

- Rugged and robust
- Overload clutch (set to 1,2 – 1,5 × max. permissible load)
- Motor with auto reset thermal overload protection
- Acme or ball screw drive
- Holding brake prevents back driving on ball screw models
- Acme screw models are self-locking
- Anti coast brake on all ball screw models (optional on acme models)
- Safety nut on all ball screw models
- Can operate in a large temperature range
- Accepts large input voltage variations
- Maintenance free

## Options

- Potentiometer feedback
- Hand wind
- Custom RAL color

## Engineering notes

- Capacitor (10 µF) necessary on 230 Vac models, p/no. D9200-448-003

## Performance table

Model	Max. dynamic load [N]	Speed @ min. load [mm/s]	Speed @ max. load [mm/s]
A22-05A5	1100	48	38
A22-05B5	2250	61	37
A42-05B5	2250	61	37
A22-10A5	2250	30	18
A42-10A5	2250	30	18
A22-10B5	4500	30	19
A42-10B5	4500	30	19
A22-20A5	2250	15	12
A42-20A5	2250	15	12
A22-20B5	4500	15	12
A42-20B5	4500	15	12
A22-21B5	6800	15	11
A42-21B5	6800	15	11

## Standard strokes

Bestellter Hub [Zoll]	Tatsächlicher Hub S [mm]
4	101,6
6	152,4
8	203,2
10	254,0
12	304,8
14	355,6
16	406,4
18	457,2
20	508,0
24	609,6

## Dimensions

### Acme screw driven models

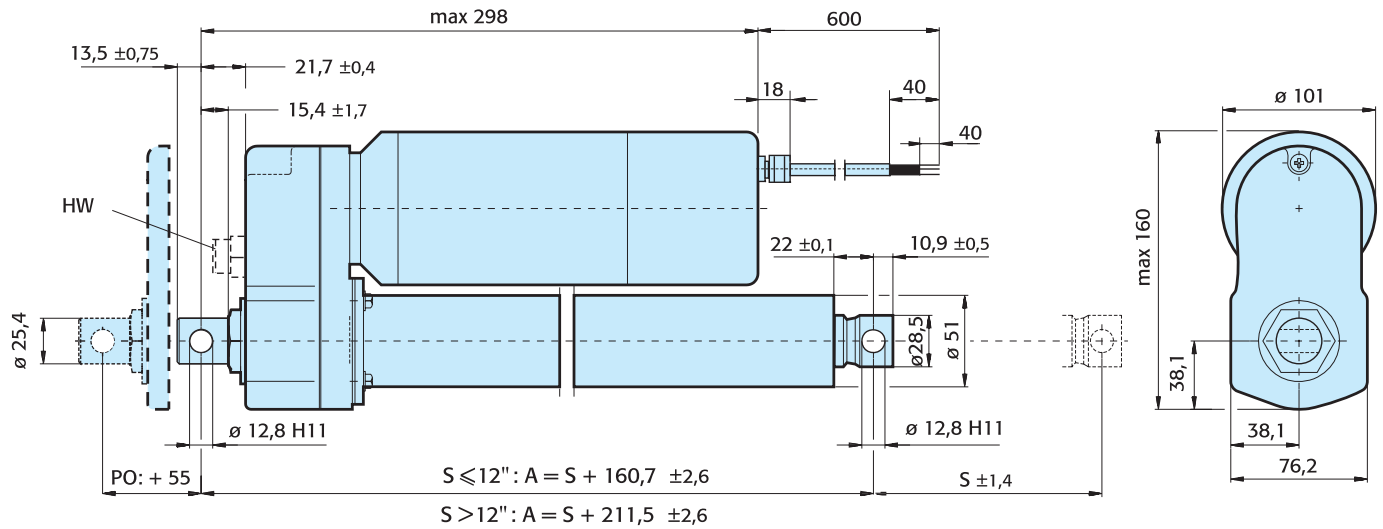

### Ball screw driven models

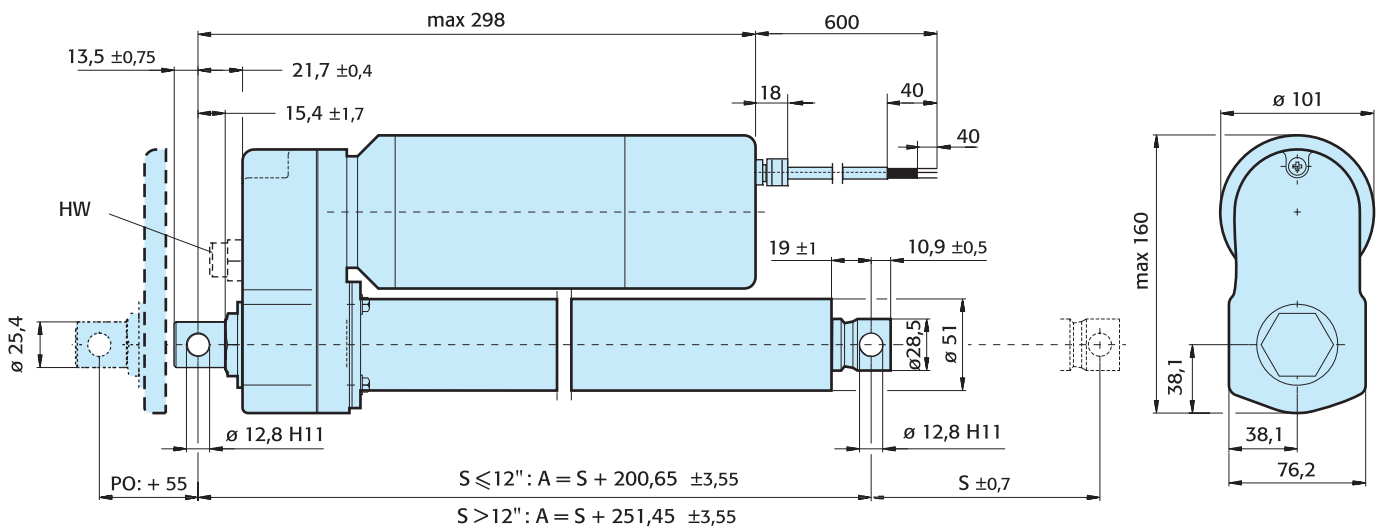

## Performance diagrams

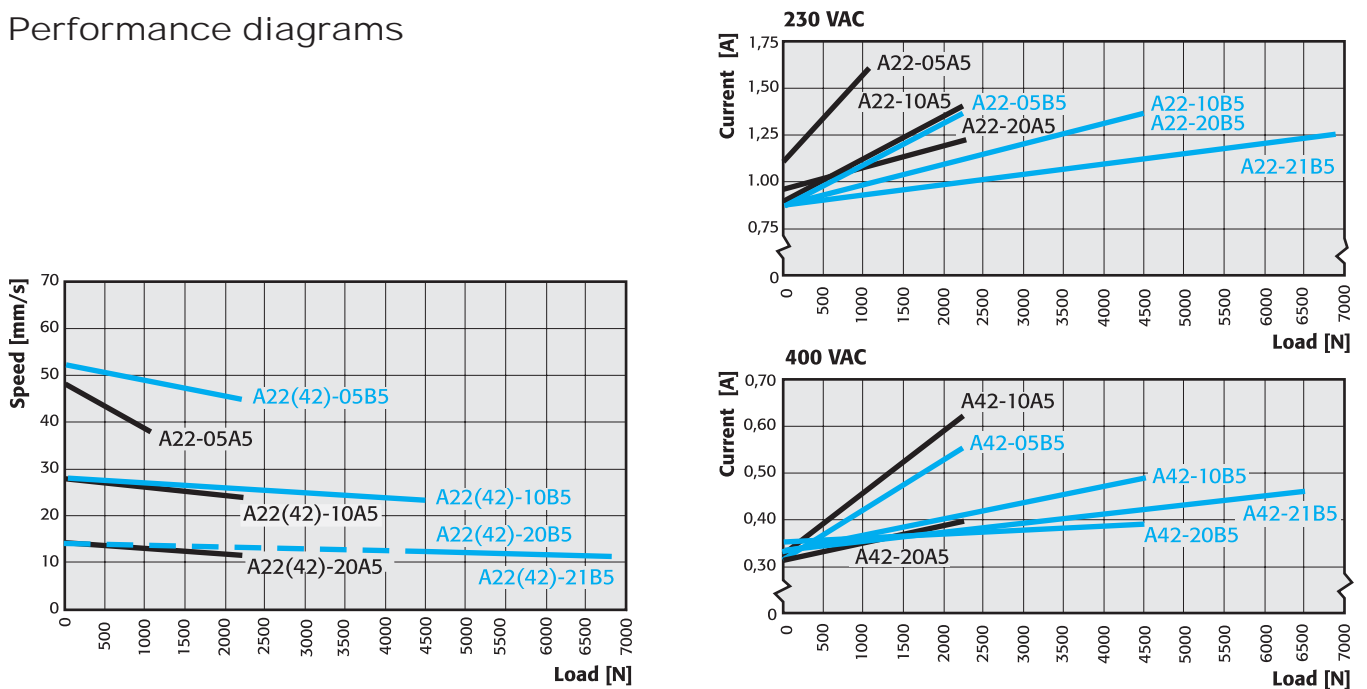

## Technical data

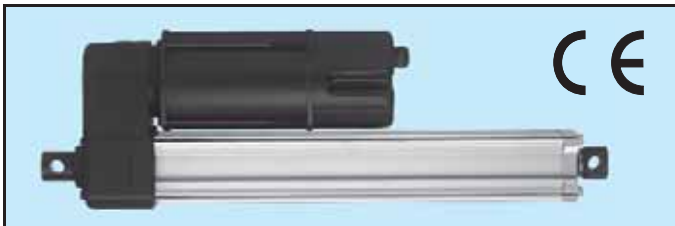

Available input voltages [Vac]	1 x 230 or 3 x 400
Input frequency [Hz]	50
Available screw types	Acme or Ball
Max. static load at fully retracted [N]	
Acme screw models	11 350
Ball screw models	18 000
Min. / max. standard stroke [mm]	50 / 600
Duty cycle @ 25° C [%]	25
Max. operation time [s]	45
Temperature limits at operation [°C]	- 25 to + 65
Protection degree	IP45
Max. end play [mm]	1
Restraining torque [Nm]	–
Wire cross section [mm <sup>2</sup> ]	1,5
Wire length [mm]	600
Connector included	no

## Features

- Rugged and robust
- Aluminium cover tube with T-slot
- Position sensors can be fitted to the T-slots
- Trunnion mounting possible
- Anti rotation mechanism
- Withstand 96 hour salt spray test
- Overload clutch (set to 1,2 – 1,5 x max. permissible load)
- Motor with auto reset thermal overload protection
- Acme or ball screw drive
- Holding brake prevents back driving on ball screw models
- Acme screw models are self-locking
- Safety nut on all ball screw models
- Can operate in a large temperature range
- Accepts large input voltage variations
- Maintenance free

## Options

- Potentiometer feedback
- Hand wind
- Custom RAL color

## Engineering notes

- Capacitor (10 µF) necessary on 230 Vac models

## Performance table

Model	Max. dynamic load [N]	Speed @ min. load [mm/s]	Speed @ max. load [mm/s]
AA22-05A65	1100	48	38
AA22-05B65	2250	52	45
AA42-05B65	2250	52	45
AA22-10A65	2250	28	24
AA42-10A65	2250	28	24
AA22-10B65	4500	28	24
AA42-10B65	4500	28	24
AA22-20A65	2250	14	11
AA42-20A65	2250	14	11
AA22-20B65	4500	14	11
AA42-20B65	4500	14	11
AA22-21B65	6800	12	11
AA42-21B65	6800	12	11

## Standard strokes

Ordering stroke [cm]	Actual stroke S [mm]
5	50
10	100
15	150
20	200
25	250
30	300
35	350
40	400
45	450
50	500
55	550
60	600



## Dimensions

### Acme screw driven models

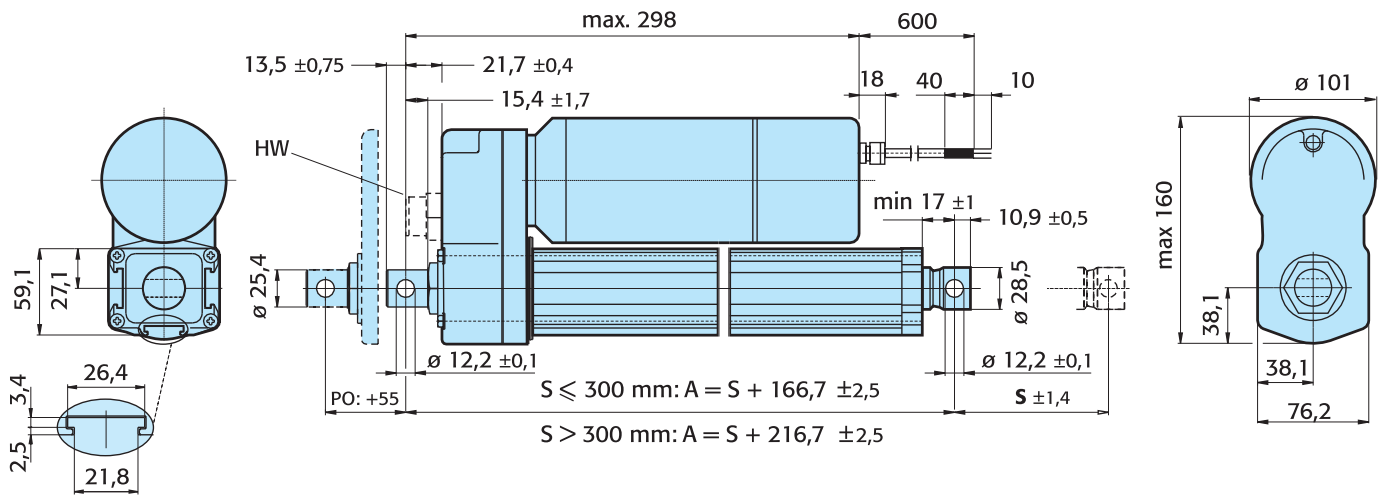

### Ball screw driven models

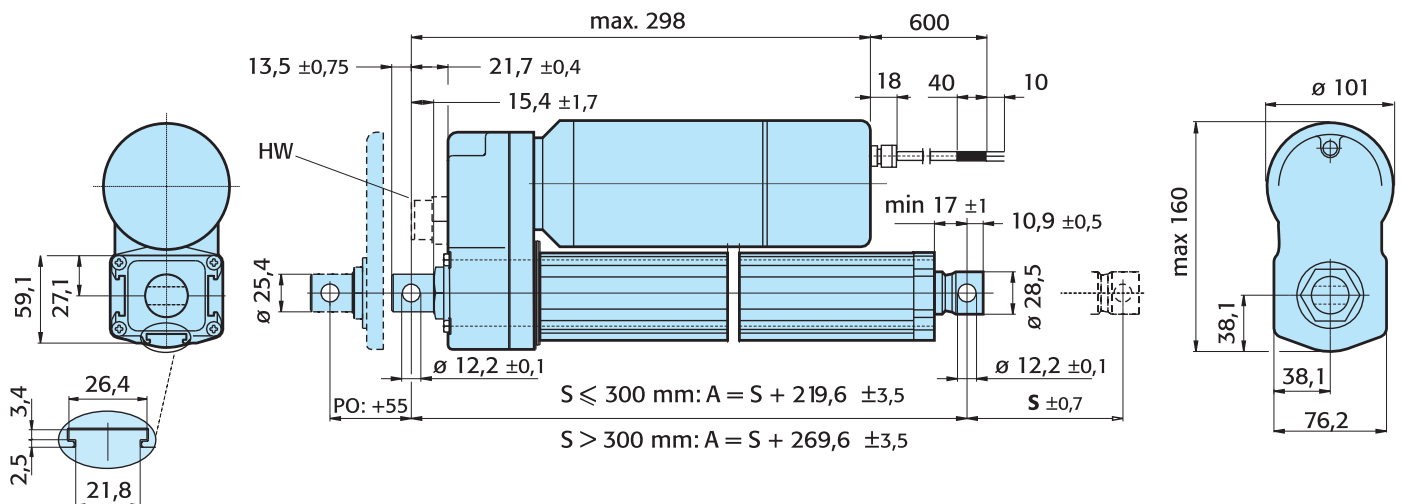

## Performance diagrams

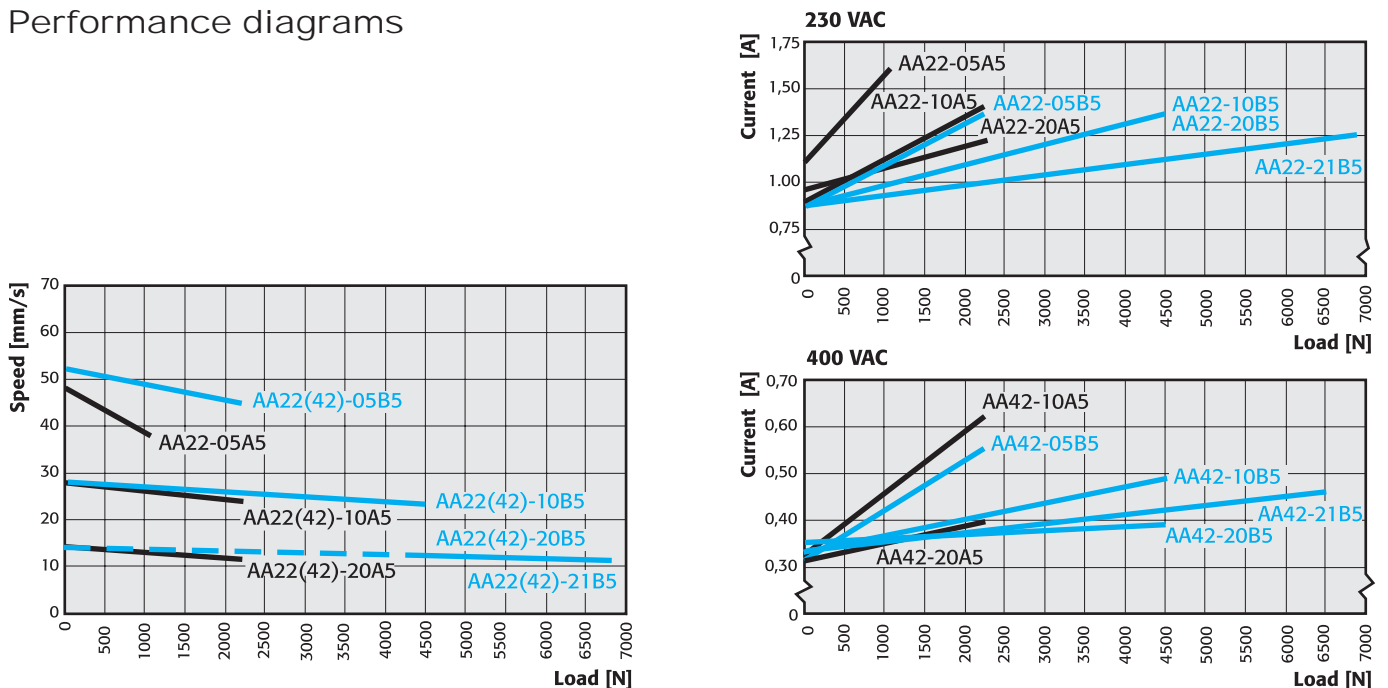

## Technical data



Available screw types	Acme or Ball
Max. static load at fully retracted [N]	
Acme screw models	11 350
Ball screw models	18 000
Min. / max. standard stroke [mm]	100 / 600
Max. input speed [rpm]	3000
Max. input torque [Nm]	1,8
Max. end play [mm]	1
Restraining torque [Nm]	–

## Features

- Rugged and robust
- Motor fitted by customer
- Aluminium cover tube with T-slot
- Position sensors can be fitted to the T-slots
- Trunnion mounting possible
- Anti rotation mechanism
- Overload clutch (set to 1,2 – 1,5 × max. permissible load)
- Acme or ball screw drive
- Holding brake prevents back driving on ball screw models
- Acme screw models are self-locking
- Safety nut on all ball screw models
- Maintenance free

## Options

- Hand wind
- Custom RAL color

## Performance table

Model	Max. dynamic load [N]	Speed @ max. load [mm/s]*
FA14-05A65	1100	32
FA14-05B65	2250	37
FA14-10A65	2250	18
FA14- 0B65	4500	19
FA14-20A65	2250	12
FA14-20B65	4500	12
FA14-21B65	6800	11

\*Recommended value

## Standard strokes

Ordering stroke [cm]	Actual stroke S [mm]
5	50
10	100
15	150
20	200
25	250
30	300
35	350
40	400
45	450
50	500
55	550
60	600

## Dimensions

### Acme screw driven models

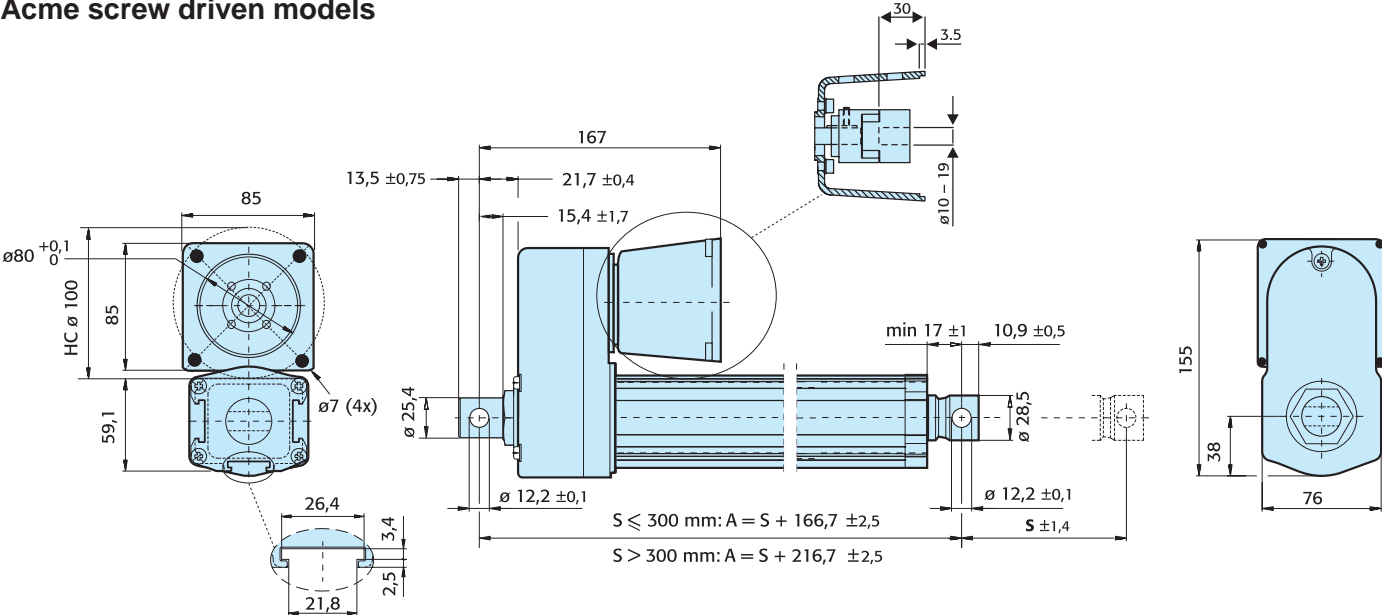

### Ball screw driven models

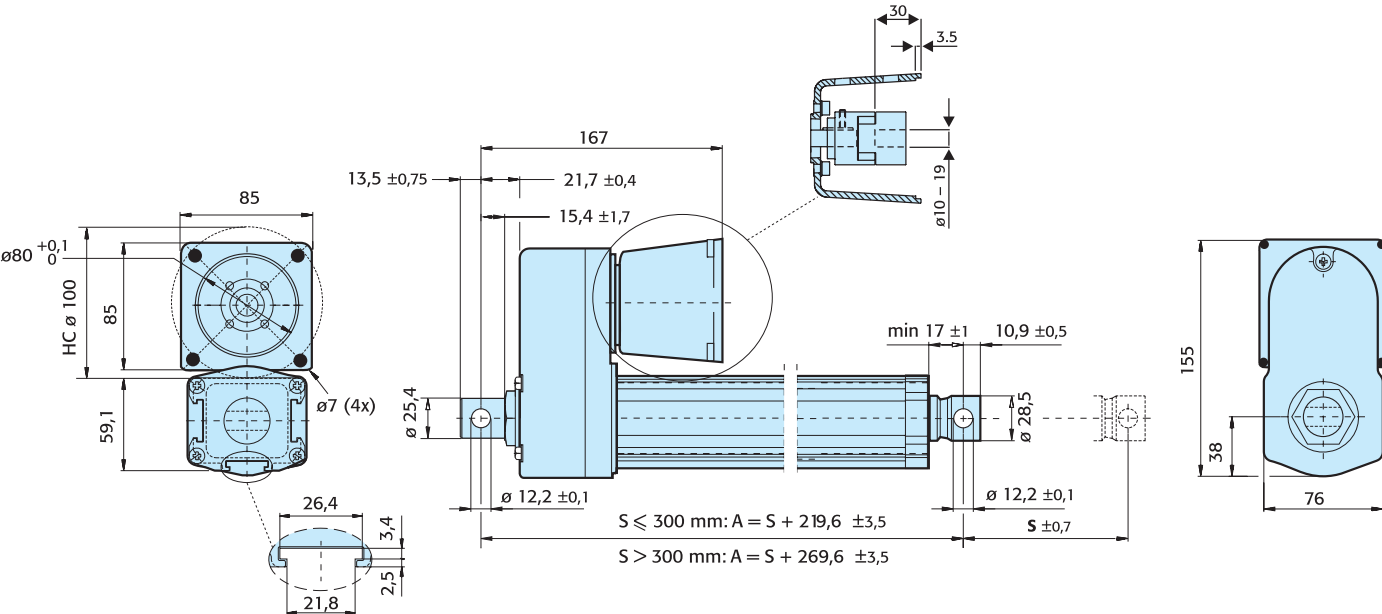

## Electrak LA1-S

Designation example	<b>S</b>	<b>12</b>	<b>-</b>	<b>09A04</b>	<b>-</b>	<b>02</b>
<b>Actuator type</b> LA1-S (with end of stroke limit switches)	<b>S</b>					
<b>Supply voltage</b> 12 Vdc 24 Vdc 36 Vdc		<b>12</b> <b>24</b> <b>36</b>				
<b>Hyphen</b>			<b>-</b>			
<b>Gear ratio / screw type / screw lead</b> 9:1 / acme screw / 6,35 mm 9:1 / acme screw / 3,18 mm 17:1 / acme screw / 3,18 mm 17:1 / acme screw / 1,59 mm				<b>09A04</b> <b>09A08</b> <b>17A08</b> <b>17A16</b>		
<b>Hyphen</b>					<b>-</b>	
<b>Stroke</b> 21 mm 46 mm 72 mm 97 mm 122 mm 148 mm						<b>01</b> <b>02</b> <b>03</b> <b>04</b> <b>05</b> <b>06</b>

## Electrak LA1-SP

Designation example	<b>SP</b>	<b>12</b>	<b>-</b>	<b>09A04</b>	<b>-</b>	<b>02</b>
<b>Actuator type</b> LA1-SP (with feedback potentiometer)	<b>SP</b>					
<b>Supply voltage</b> 12 Vdc 24 Vdc 36 Vdc		<b>12</b> <b>24</b> <b>36</b>				
<b>Hyphen</b>			<b>-</b>			
<b>Gear ratio / screw type / screw lead</b> 9:1 / acme screw / 6,35 mm 9:1 / acme screw / 3,18 mm 17:1 / acme screw / 3,18 mm 17:1 / acme screw / 1,59 mm (not possible with 171,5 mm stroke)				<b>09A04</b> <b>09A08</b> <b>17A08</b> <b>17A16</b>		
<b>Hyphen</b>					<b>-</b>	
<b>Stroke</b> 59 mm 115 mm 172 mm (not possible with gear and screw combination 17A16)						<b>02</b> <b>04</b> <b>06</b>



## Electrak LA10

Designation example	<b>D</b>	<b>24</b>	<b>-</b>	<b>10B5</b>	<b>-</b>	<b>06</b>	<b>M0</b>	<b>N</b>	
<b>Actuator type</b> LA10	D								
<b>Supply voltage</b> 12 Vdc 24 Vdc 36 Vdc		12 24 36							
<b>Hyphen</b>			-						
<b>Gear ratio / screw type / screw lead</b> 5:1 / acme screw / 5,08 mm 10:1 / acme screw / 5,08 mm 20:1 / acme screw / 5,08 mm 5:1 / ball screw / 5,08 mm 10:1 / ball screw / 5,08 mm 20:1 / ball screw / 5,08 mm 20:1 / ball screw / 5,08 mm with hardened gear				05A5 10A5 20A5 05B5 10B5 20B5 21B5					
<b>Engineering unit</b> Inch					-				
<b>Stroke</b> 4 inch (102 mm) 6 inch (152 mm) 8 inch (203 mm) 10 inch (254 mm) 12 inch (305 mm) 14 inch (356 mm) 16 inch (406 mm) 18 inch (457 mm) 20 inch (508 mm) 24 inch (610 mm)						04 06 08 10 12 14 16 18 20 24			
<b>Adaptor hole position (for definition see page 26)</b> Rear adaptor 0° (standard position) Rear adaptor 30° Rear adaptor 60° Rear adaptor 90° Rear adaptor 120° Rear adaptor 150°							M0 M1 M2 M3 M4 M5		
<b>Anti coast brake</b> No anti coast brake								N	
<b>Options</b> No option - leave position blank Feedback potentiometer Hand wind									PO HW

## Electrak LA14

Designation example	DA	24	-	20A65	M	25	MF	N	PO
<b>Actuator type</b> LA14	DA								
<b>Supply voltage</b> 12 Vdc 24 Vdc 36 Vdc		12 24 36							
<b>Hyphen</b>			-						
<b>Gear ratio / screw type / screw diameter / screw lead</b> 5:1 / acme screw / 15,88 mm / 5,08 mm 10:1 / acme screw / 15,88 mm / 5,08 mm 20:1 / acme screw / 15,88 mm / 5,08 mm 5:1 / ball screw / 15,88 mm / 5,08 mm 10:1 / ball screw / 15,88 mm / 5,08 mm 20:1 / ball screw / 15,88 mm / 5,08 mm 20:1 / ball screw / 15,88 mm / 5,08 mm with hardened gear				05A65 10A65 20A65 05B65 10B65 20B65 21B65					
<b>Engineering unit</b> Metric					M				
<b>Stroke</b> 5 cm 10 cm 15 cm 20 cm 25 cm 30 cm 35 cm 40 cm 45 cm 50 cm 55 cm 60 cm						05 10 15 20 25 30 35 40 45 50 55 60			
<b>Adaptor hole position (for definition see page 26)</b> Rear adaptor 0° (standard position) Rear adaptor 30° Rear adaptor 60° Rear adaptor 90° Rear adaptor 120° Rear adaptor 150° Rear and front adaptor 90°							M0 M1 M2 M3 M4 M5 MF		
<b>Anti coast brake</b> No anti coast brake								N	
<b>Options</b> No option - leave position blank Feedback potentiometer Hand wind									PO HW

## Electrak LA5

Designation example	<b>A</b>	<b>22</b>	<b>-</b>	<b>10B5</b>	<b>-</b>	<b>04</b>	<b>M0</b>	<b>B</b>	<b>HW</b>
<b>Actuator type</b> LA5	<b>A</b>								
<b>Supply voltage</b> 1 × 230 Vac, 50 Hz 3 × 400 Vac, 50 Hz		<b>22</b> <b>42</b>							
<b>Hyphen</b>			<b>-</b>						
<b>Gear ratio / screw type / screw diameter / screw lead</b> 5:1 / acme screw / 15,88 mm / 5,08 mm (not possible with 400 Vac motor) 10:1 / acme screw / 15,88 mm / 5,08 mm 20:1 / acme screw / 15,88 mm / 5,08 mm 5:1 / ball screw / 15,88 mm / 5,08 mm 10:1 / ball screw / 15,88 mm / 5,08 mm 20:1 / ball screw / 15,88 mm / 5,08 mm 20:1 / ball screw / 15,88 mm / 5,08 mm with hardened gear				<b>05A5</b> <b>10A5</b> <b>20A5</b> <b>05B5</b> <b>10B5</b> <b>20B5</b> <b>21B5</b>					
<b>Engineering unit</b> Inch					<b>-</b>				
<b>Stroke</b> 4 inch (102 mm) 6 inch (152 mm) 8 inch (203 mm) 10 inch (254 mm) 12 inch (305 mm) 14 inch (356 mm) 16 inch (406 mm) 18 inch (457 mm) 20 inch (508 mm) 24 inch (610 mm)						<b>04</b> <b>06</b> <b>08</b> <b>10</b> <b>12</b> <b>14</b> <b>16</b> <b>18</b> <b>20</b> <b>24</b>			
<b>Adaptor hole position (for definition see page 26)</b> Rear adaptor 0° (standard position) Rear adaptor 30° Rear adaptor 60° Rear adaptor 90° Rear adaptor 120° Rear adaptor 150°							<b>M0</b> <b>M1</b> <b>M2</b> <b>M3</b> <b>M4</b> <b>M5</b>		
<b>Anti coast brake</b> No anti coast brake Anti coast brake								<b>N</b> <b>B</b>	
<b>Options</b> No option - leave position blank Feedback potentiometer Hand wind									<b>PO</b> <b>HW</b>

## Electrak LA24

Designation example	AA	42	-	20A65	M	30	M3	N	HW
<b>Actuator type</b> LA24	AA								
<b>Supply voltage</b> 1 × 230 Vac, 50 Hz 3 × 400 Vac, 50 Hz		22 42							
<b>Hyphen</b>			-						
<b>Gear ratio / screw type / screw diameter / screw lead</b> 5:1 / acme screw / 15,88 mm / 5,08 mm (not possible with 400 Vac motor) 10:1 / acme screw / 15,88 mm / 5,08 mm 20:1 / acme screw / 15,88 mm / 5,08 mm 5:1 / ball screw / 15,88 mm / 5,08 mm 10:1 / ball screw / 15,88 mm / 5,08 mm 20:1 / ball screw / 15,88 mm / 5,08 mm 20:1 / ball screw / 15,88 mm / 5,08 mm with hardened gear				05A65 10A65 20A65 05B65 10B65 20B65 21B65					
<b>Engineering unit</b> Metric					M				
<b>Stroke</b> 5 cm 10 cm 15 cm 20 cm 25 cm 30 cm 35 cm 40 cm 45 cm 50 cm 55 cm 60 cm						05 10 15 20 25 30 35 40 45 50 55 60			
<b>Adaptor hole position (for definition see page 26)</b> Rear adaptor 0° (standard position) Rear adaptor 30° Rear adaptor 60° Rear adaptor 90° Rear adaptor 120° Rear adaptor 150° Rear and front adaptor 90°							M0 M1 M2 M3 M4 M5 MF		
<b>Anti coast brake</b> No anti coast brake Anti coast brake								N B	
<b>Options</b> No option - leave position blank Feedback potentiometer Hand wind									PO HW



## Electrak FA14

Designation example	FA14	-	10A65	M	40	M0	N	
<b>Actuator type</b> FA14 (actuator without motor)	FA14							
<b>Hyphen</b>		-						
<b>Gear ratio / screw type / screw diameter / screw lead</b>								
5:1 / acme screw / 15,88 mm / 5,08 mm			05A65					
10:1 / acme screw / 15,88 mm / 5,08 mm			10A65					
20:1 / acme screw / 15,88 mm / 5,08 mm			20A65					
5:1 / ball screw / 15,88 mm / 5,08 mm			05B65					
10:1 / ball screw / 15,88 mm / 5,08 mm			10B65					
20:1 / ball screw / 15,88 mm / 5,08 mm			20B65					
20:1 / ball screw / 15,88 mm / 5,08 mm with hardened gear			21B65					
<b>Engineering unit</b> Millimeter				M				
<b>Stroke</b>								
5 cm					05			
10 cm					10			
15 cm					15			
20 cm					20			
25 cm					25			
30 cm					30			
35 cm					35			
40 cm					40			
45 cm					45			
50 cm					50			
55 cm					55			
60 cm					60			
<b>Adaptor hole position (for definition see page 26)</b>								
Rear adaptor 0° (standard position)						M0		
Rear adaptor 30°						M1		
Rear adaptor 60°						M2		
Rear adaptor 90°						M3		
Rear adaptor 120°						M4		
Rear adaptor 150°						M5		
Rear and front adaptor 90°						MF		
<b>Anti coast brake</b> No anti coast brake							N	
<b>Options</b> No option - leave position blank Hand wind								HW

## Rear adaptor hole position

LA5  
LA10  
LA14  
LA24  
FA14

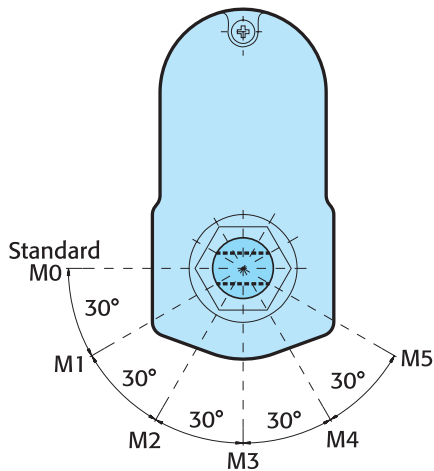

## Hand wind

LA5  
LA10  
LA14  
LA24  
FA14

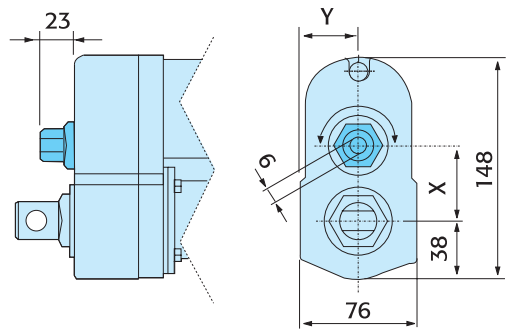

Gear ratio	X	Y
5:1	49,6	38,0
10:1	43,3	43,2
20:1	38,9	38,0

## Rear and front adaptor hole in 90°

LA14  
LA24  
FA14

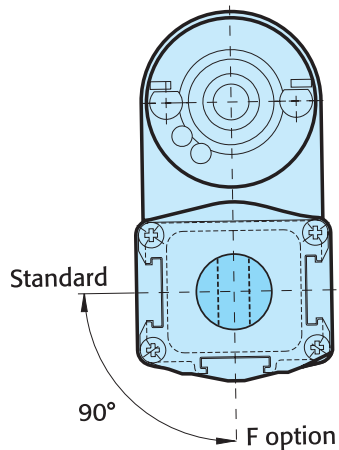

## Sensors

LA14  
LA24  
FA14

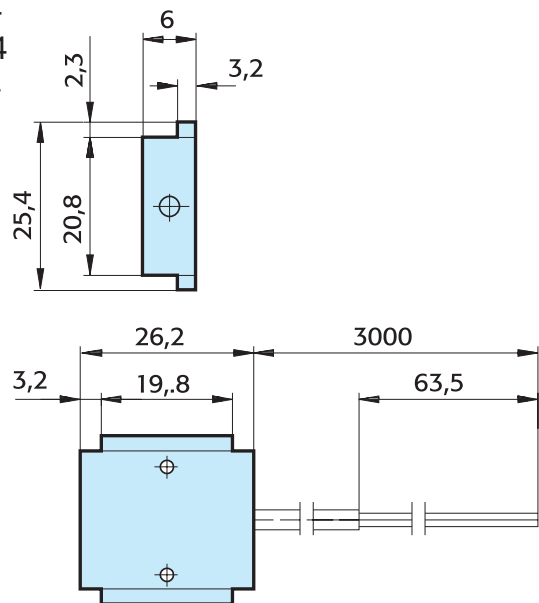

Sensor data	
Max. power [W]	10
Max. voltage [Vdc]	43,3
Max. current [A]	0,5
Max. contact resistance [ohm]	0,2
Lead data [mm <sup>2</sup> ]	0,12

## Capacitor

LA5  
LA24

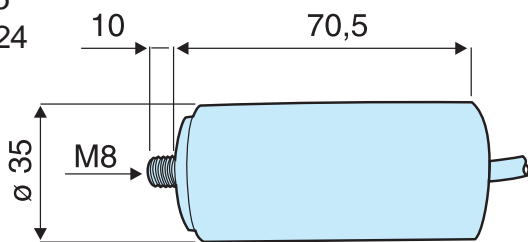

Cable: 2 x 0,75 mm<sup>2</sup>, length 170 mm

A 10 µF capacitor is necessary for all 1 x 230 Vac actuators.

Capacitor 10 µF

D9200-448-003

Normally open	D535 070
Normally closed	D535 071

Mounting pins

LA5  
LA10

Max. 51  
 $\phi 12,7$

LA14  
LA24  
FA14

Max. 51  
 $\phi 12$

LA5, LA10 (2 x)	D603 028
LA14, LA24, FA14 (2 x)	D603 023

Mounting pin brackets

LA14  
LA24  
FA14

23  
15,5  
45  
30  
33  
53  
6,6 (4x)  
max. 51

LA14, LA24, FA14 (2 x)	D603 029
------------------------	----------

Trunnion pins

LA14  
LA24  
FA14

16  
 $\phi 16$   
38

LA14, LA24, FA14 (2 x)	D603 022
------------------------	----------

Trunnion pin brackets

LA14  
LA24  
FA14

134  
 $\phi 9 (4x)$   
9,5  
35  
24  
65  
82

LA14, LA24, FA14 (2 x)	D603 030
------------------------	----------

---

– Page intentionally left blank –

## Elektrak PPA-DC

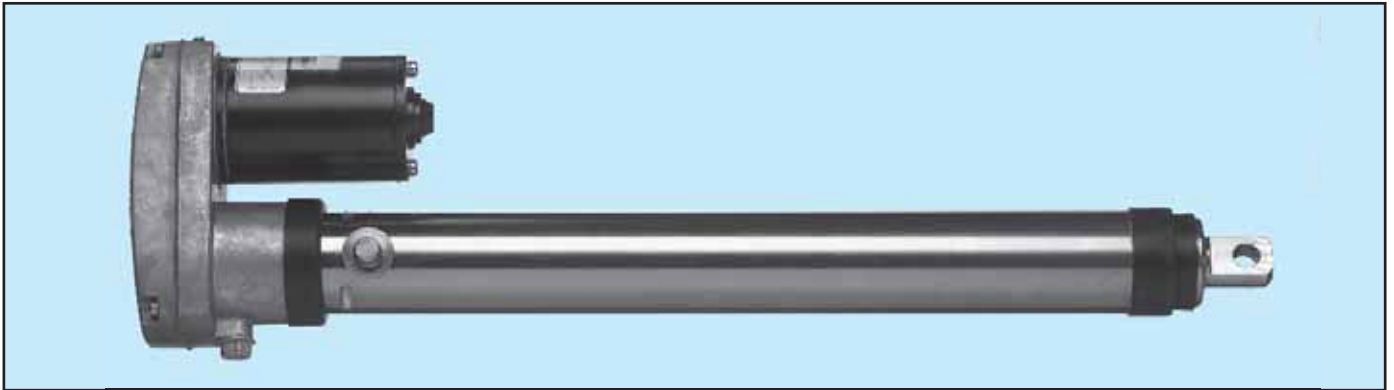

- Robust and versatile
- Trunnion to clevis mounting
- 12, 24 or 36 Vdc
- Ball screw driven
- Stroke from 102 to 914 mm
- Speed from 12 to 33 mm/s
- Load up to 6670 N
- Maintenance free
- End of stroke limit switches available as option
- Feedback potentiometer available as option
- Hall effect position sensor available as option

## Elektrak PPA-AC



- Robust and versatile
- Trunnion to clevis mounting
- 110 or 230 Vac power supply
- Ball screw driven
- Stroke from 102 to 914 mm
- Speed from 5 to 15 mm/s
- Load up to 6670 N
- Motor with auto reset thermal overload protection
- Maintenance free
- End of stroke limit switches available as option
- Feedback potentiometer available as option
- Hall effect position sensor available as option



## Technical data



Available input voltages [Vdc]	12, 24 or 36
Available screw types	Ball
Max. static load at fully retracted [N]	13 350
Min. / max. standard stroke [inch]	4 / 36
Duty cycle @ 20° C [%]	30
Temperature limits at operation [°C]	- 25 to + 65
Max. end play [mm]	1
Wire cross section [mm <sup>2</sup> ]	2
Wire length [mm]	400
Connector included	no

## Features

- Robust and versatile
- Overload clutch
- Ball screw drive
- Holding brake prevents back driving
- Can operate in a large temperature range
- Accepts large input voltage variations
- Maintenance free
- Trunnion to clevis mounting

## Options

- Potentiometer feedback
- Hall effect feedback
- End of stroke limit switches
- Protective bellows

## Performance table

Model	Max. dynamic load [N]	Speed @ min. load [mm/s]	Speed @ max. load [mm/s]
PPA12-18B65	3330	33	28
PPA24-18B65	3330	33	28
PPA36-18B65	3330	33	28
PPA12-58B65	6670	12	10
PPA24-58B65	6670	12	10
PPA36-58B65	6670	12	10

## Standard strokes

Ordering stroke [inch]	Actual stroke S [mm]
4	102
8	203
12	305
18	457
24	610
36	914

Dimensions

12, 24 and 36 Vdc models

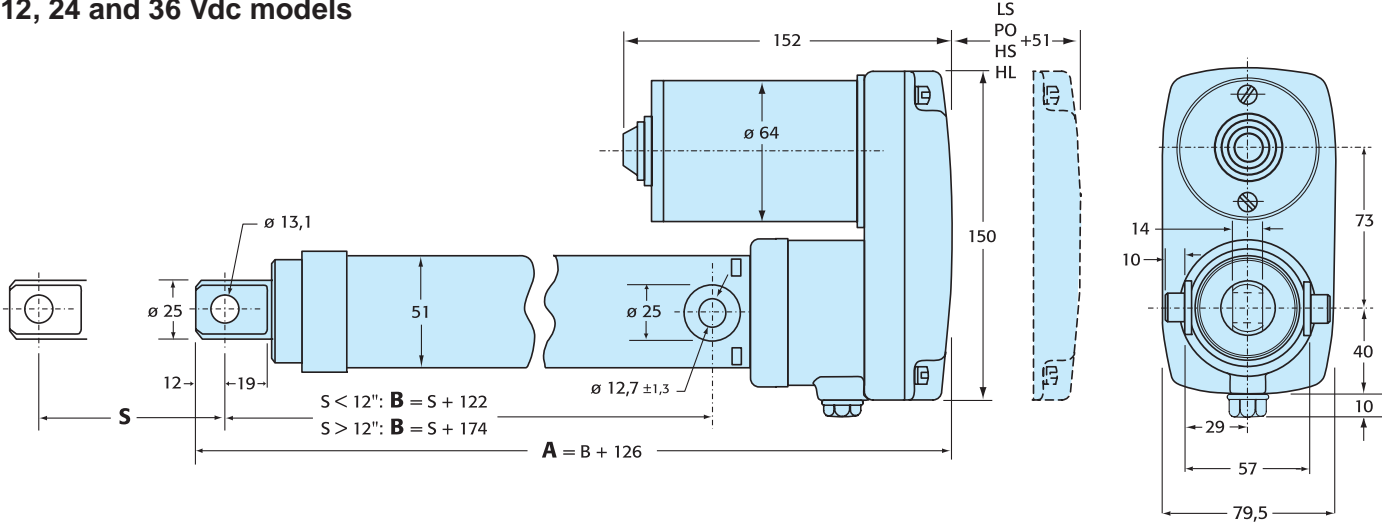

Performance diagrams

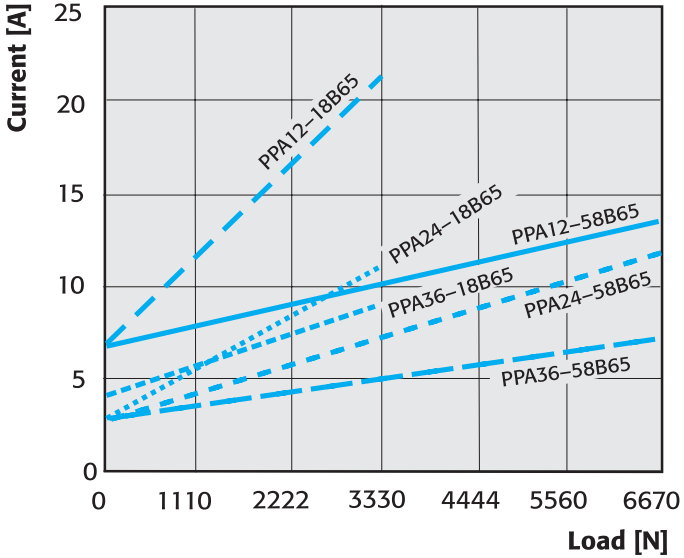
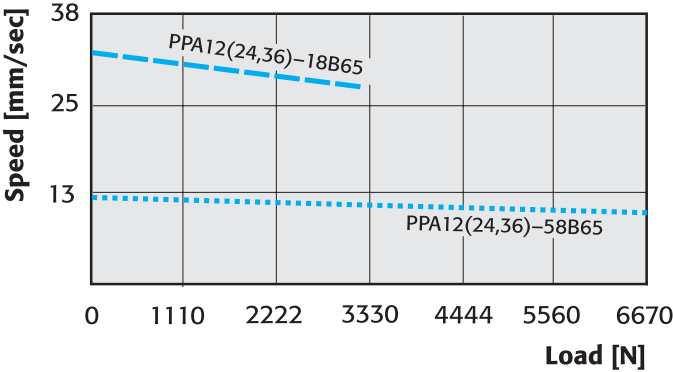

## Technical data



Available input voltages [Vac]	1 x 110 or 1 x 230
Input frequency [Hz]	50 / 60
Available screw types	Ball
Max. static load at fully retracted [N]	13 350
Min. / max. standard stroke [inch]	4 / 36
Max. coast distance (without anti coast or electrical brake option) [mm]	1,6
Duty cycle @ 20° C [%]	30
Temperature limits at operation [°C]	- 25 to + 65
Max. end play [mm]	1
Wire cross section [mm <sup>2</sup> ]	0,75
Wire length [mm]	500
Connector included	no

## Features

- Robust and versatile
- Overload clutch
- Motor with auto reset thermal overload protection
- Ball screw drive
- Holding brake prevents back driving
- Can operate in a large temperature range
- Accepts large input voltage variations
- Maintenance free
- Built in capacitor
- Trunnion to clevis mounting

## Options

- Anti coast brake on 110 and 230 Vac models
- Electrical brake on 110 Vac models
- Potentiometer feedback
- Hall effect feedback
- End of stroke limit switches
- Protective bellows

## Performance table

Model	Max. dynamic load [N]	Speed @ min. load [mm/s]	Speed @ max. load [mm/s]
PPA11-18B65	2220	15	14
PPA22-18B65	2220	12,5	12
PPA11-58B65	6670	5	5
PPA22-58B65	6670	5	5

## Standard strokes

Ordering stroke [inch]	Actual stroke S [mm]
4	102
8	203
12	305
18	457
24	610
36	914

Dimensions

110 and 230 Vac models

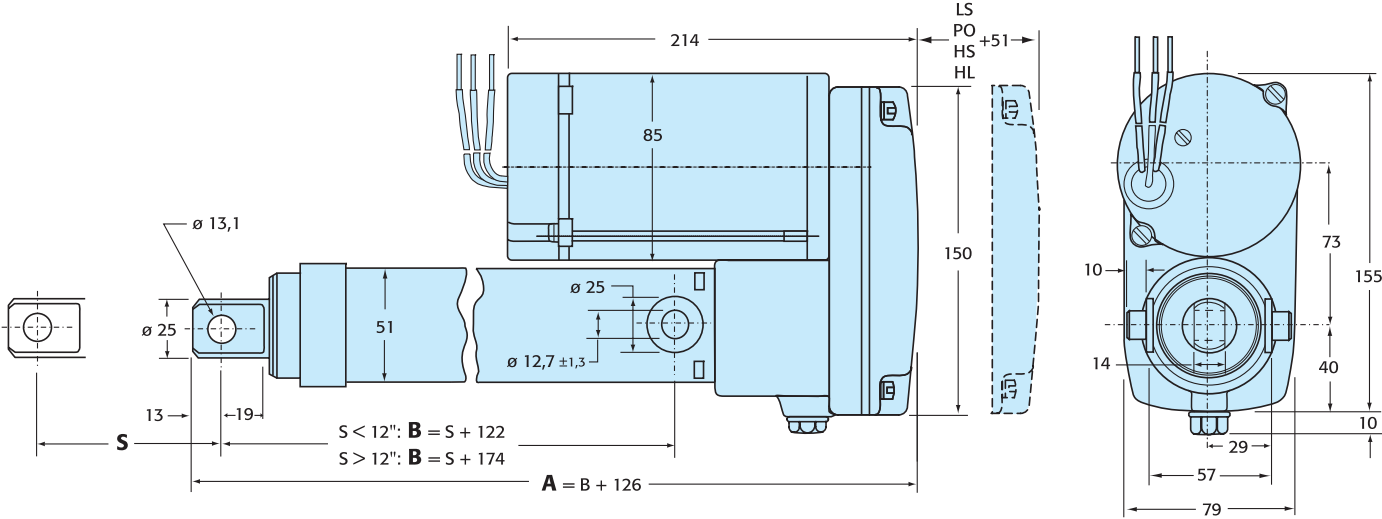

110, 230 Vac models with anti coast brake or 110 Vac models with electrical brake

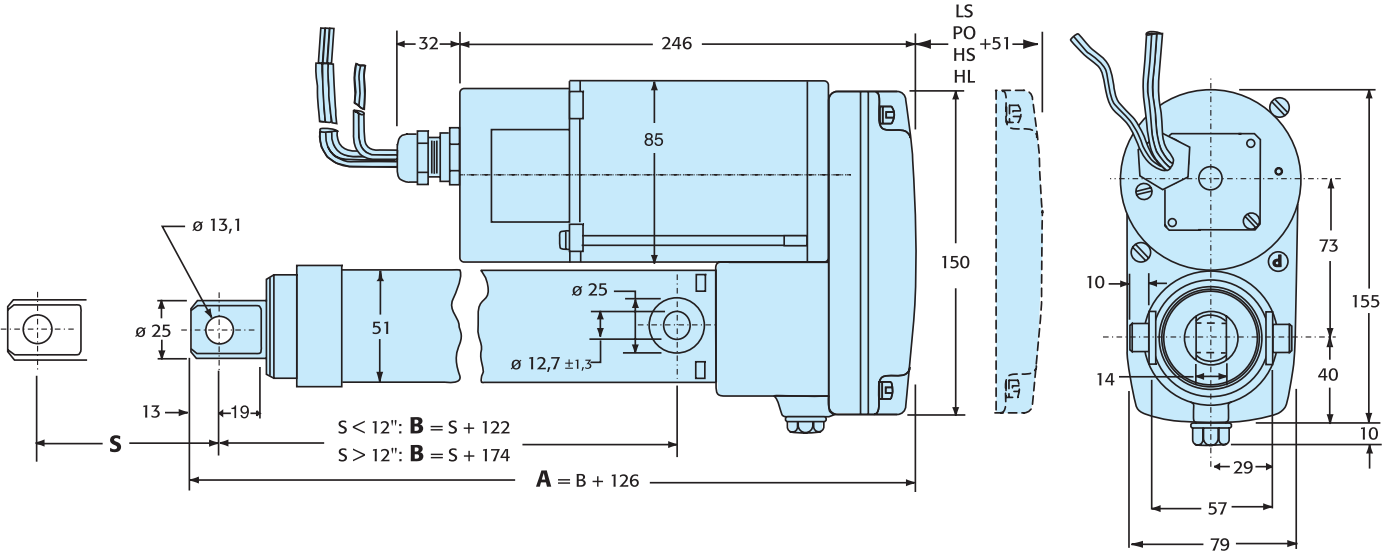

Performance diagrams

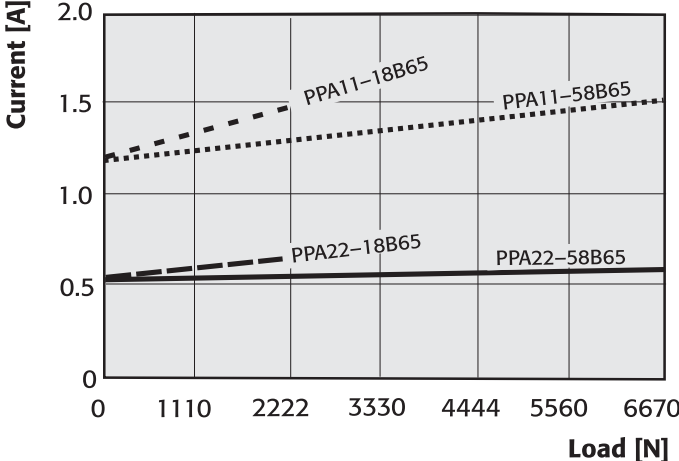
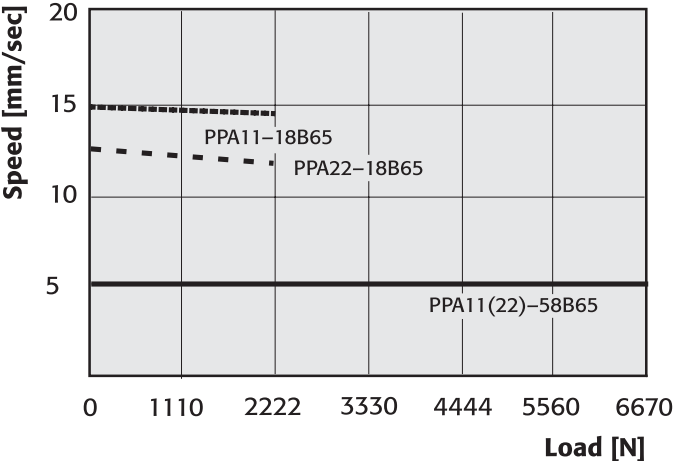

## Technical data

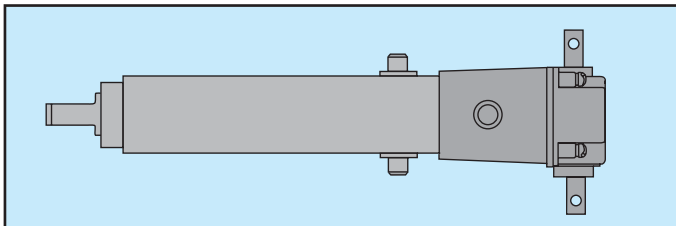

Available screw types	Ball
Max. static load at fully retracted [N]	13 350
Min. / max. standard stroke [inch]	4 / 36
Max. input speed [rpm]	100
Max. input torque [Nm]	9
Travel per input shaft revolution [mm]	5
Max. end play [mm]	1

## Features

- Robust and versatile
- Without motor
- Operated manually or by motor fitted by the customer
- Ball screw drive
- Holding brake prevents back driving
- Maintenance free
- Trunnion to clevis mounting

## Options

- Protective bellows

## Performance table

Model	Max. dynamic load [N]	Speed @ max. load [mm/s]
PPA00-01B65	6670	8,3

## Standard strokes

Ordering stroke [inch]	Actual stroke S [mm]
4	102
8	203
12	305
18	457
24	610
36	914

## Dimensions

### Models without motor

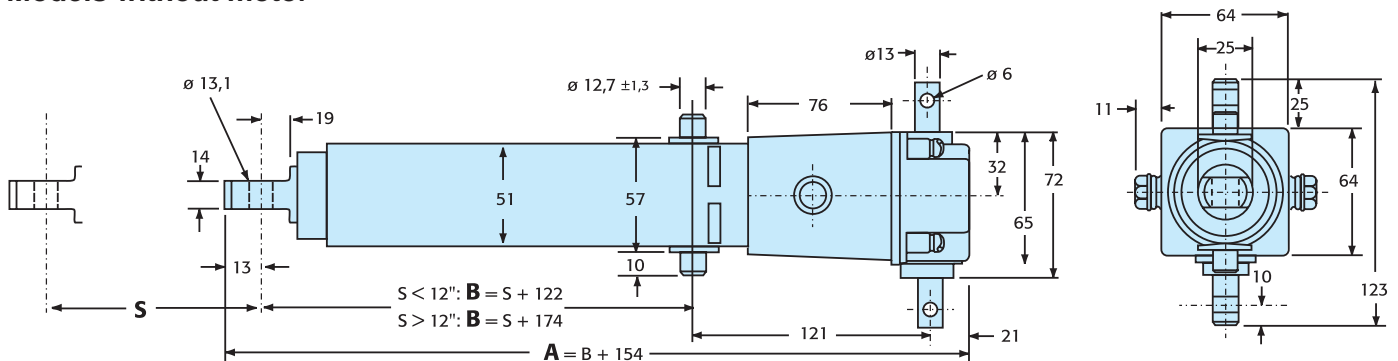

## Elecktrak PPA-DC

Designation example	PPA36-	18B65	-	12	N-	PO	C
<b>Actuator type and supply voltage</b> PPA, 12 Vdc PPA, 24 Vdc PPA, 36 Vdc	PPA12- PPA24- PPA36-						
<b>Gear ratio / screw type / screw diameter / screw lead</b> 18:1 / ball screw / 16 mm / 5 mm 58:1 / ball screw / 16 mm / 5 mm		18B65 58B65					
<b>Hyphen</b>			-				
<b>Stroke</b> 4 inch (102 mm) 6 inch (152 mm) 8 inch (203 mm) 12 inch (305 mm) 18 inch (457 mm) 24 inch (610 mm) 36 inch (914 mm)				04 06 08 12 18 24 36			
<b>Brake option</b> No anti coast brake or electrical brake					N-		
<b>Feedback option</b> No feedback option End of stroke limit switches Potentiometer feedback Hall effect sensor Hall effect sensor + end of stroke limit switches						XX LS PO HS HL	
<b>Bellows option</b> No bellows Bellows							X C

## Elecktrak PPA-AC

Designation example	PPA22-	58B65	-	06	SB	XX	X
<b>Actuator type and supply voltage</b> PPA, 1 x 110 Vac, 50/60 Hz PPA, 1 x 230 Vac, 50/60 Hz	PPA11- PPA22-						
<b>Gear ratio / screw type / screw diameter / screw lead</b> 18:1 / ball screw / 16 mm / 5 mm 58:1 / ball screw / 16 mm / 5 mm		18B65 58B65					
<b>Hyphen</b>			-				
<b>Stroke</b> 4 inch (102 mm) 6 inch (152 mm) 8 inch (203 mm) 12 inch (305 mm) 18 inch (457 mm) 24 inch (610 mm) 36 inch (914 mm)				04 06 08 12 18 24 36			
<b>Brake option</b> No anti coast brake or electrical brake Anti coast brake Electrical brake (only possible on 110 Vac models)					N- SB EB		
<b>Feedback option</b> No feedback option End of stroke limit switches Potentiometer feedback Hall effect sensor Hall effect sensor + end of stroke limit switches						XX LS PO HS HL	
<b>Bellows option</b> No bellows Bellows							X C



## Elecktrak PPA-M

Designation example	PPA00-	01B65	-	36	N-	XX	C
<b>Actuator type and supply voltage</b> PPA without motor	PPA00-						
<b>Gear ratio / screw type / screw diameter / screw lead</b> 1:1 / ball screw / 16 mm / 5 mm		01B65					
<b>Hyphen</b>			-				
<b>Stroke</b> 4 inch (102 mm) 6 inch (152 mm) 8 inch (203 mm) 12 inch (305 mm) 18 inch (457 mm) 24 inch (610 mm) 36 inch (914 mm)				04 06 08 12 18 24 36			
<b>Brake option</b> No anti coast brake or electrical brake					N-		
<b>Feedback option</b> No feedback option						XX	
<b>Bellows option</b> No bellows Bellows							X C

---

– Page intentionally left blank –

## Electrak E050



- Small, low noise and lightweight
- Shortest retracted length in the industry
- Low cost
- Load up to 510 N
- 12, 24 or 36 Vdc power supply
- Stroke from 25 to 200 mm
- Speed up to 48 mm/s
- IP 56
- Overload clutch
- End of stroke limit switches available as option
- Potentiometer feedback available as option

## Electrak Q050



- Share most features and technical data with E050
- Quiet operation
- Speed up to 38 mm/s
- IP 51

## Electrak E150

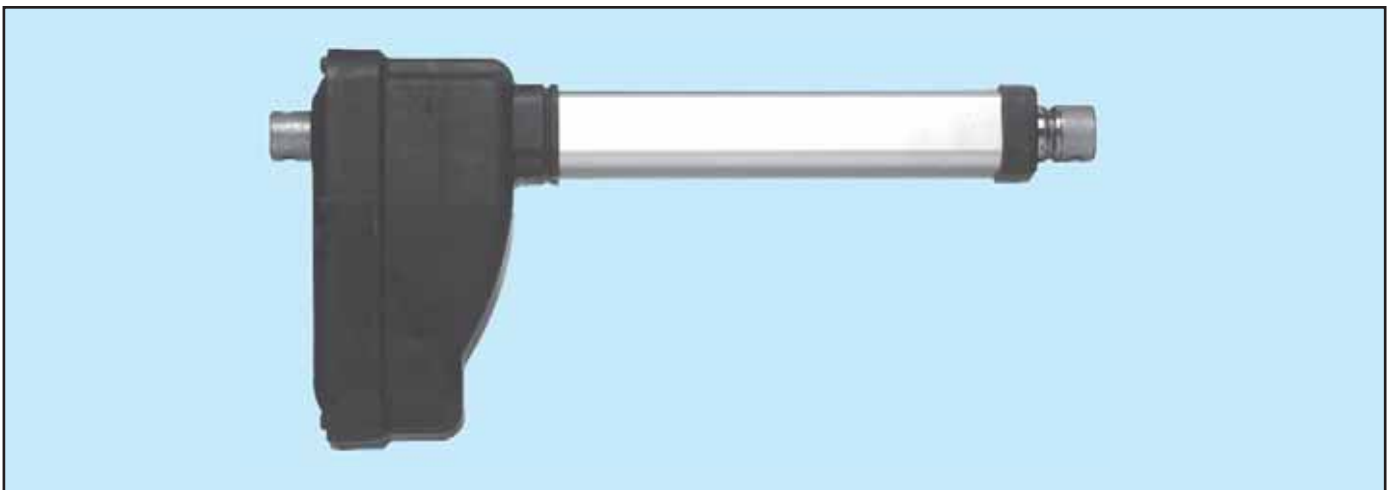

- Lightweight, flexible and durable
- Load up to 2000 N
- Speed up to 71 mm/s
- 12, 24 or 36 Vdc power supply
- Stroke from 100 to 400 mm
- IP56
- Adjustable end of stroke limit switches available as option
- Potentiometer feedback available as option

## Technical data

	
Available input voltages [Vdc]	12, 24 or 36
Screw type	Worm
Max. static load at fully retracted [N]	
DE ••• 17W41	1020
DE ••• 17W42	550
DE ••• 17W44	280
Min. / max. standard stroke [mm]	25 / 200
Duty cycle @ 20° C [%]	25
Temperature limits at operation [°C]	- 30 to + 80
Protection degree	
E050	IP56
Q050	IP51
Max. end play [mm]	1,5
Restraining torque [Nm]	–
Wire cross section [mm <sup>2</sup> ]	1
Wire length [mm]	500
Connector included	no

## Features for both E050 and Q050

- Small, quiet and lightweight
- Overload clutch
- Motor with auto reset thermal overload protection
- Anti rotation mechanism
- Estimated life is min. 40 000 cycles
- Vent tube
- Can operate in a large temperature range
- Accepts large input voltage variations
- Maintenance free

## Options

- End of stroke limit switches
- Potentiometer feedback

## Features for E050

- Speed up to 48 mm/s
- Black housing
- IP56

## Features for Q050

- Quiet
- Speed up to 38 mm/s
- White housing
- IP51

## Performance table

Model	Max. dynamic load [N]	Speed @ min. load [mm/s]	Speed @ max. load [mm/s]
DE12–17W41	510	12	9
DE24–17W41	510	12	9
DE12–17W42	275	24	18
DE24–17W42	275	24	18
DE12–17W44	140	48	37
DE24–17W44	140	48	37
DE12Q17W41	510	9	7,5
DE24Q17W41	510	9	7,5
DE12Q17W42	275	18	14
DE24Q17W42	275	18	14
DE12Q17W44	140	38	30
DE24Q17W44	140	38	30

## Standard strokes

Ordering stroke [mm]	Actual stroke S [mm]
25	25
50	50
75	75
100	100
125	125
150	150
175	175
200*	200

\*Not possible with option PO, PF and MP.

## Dimensions

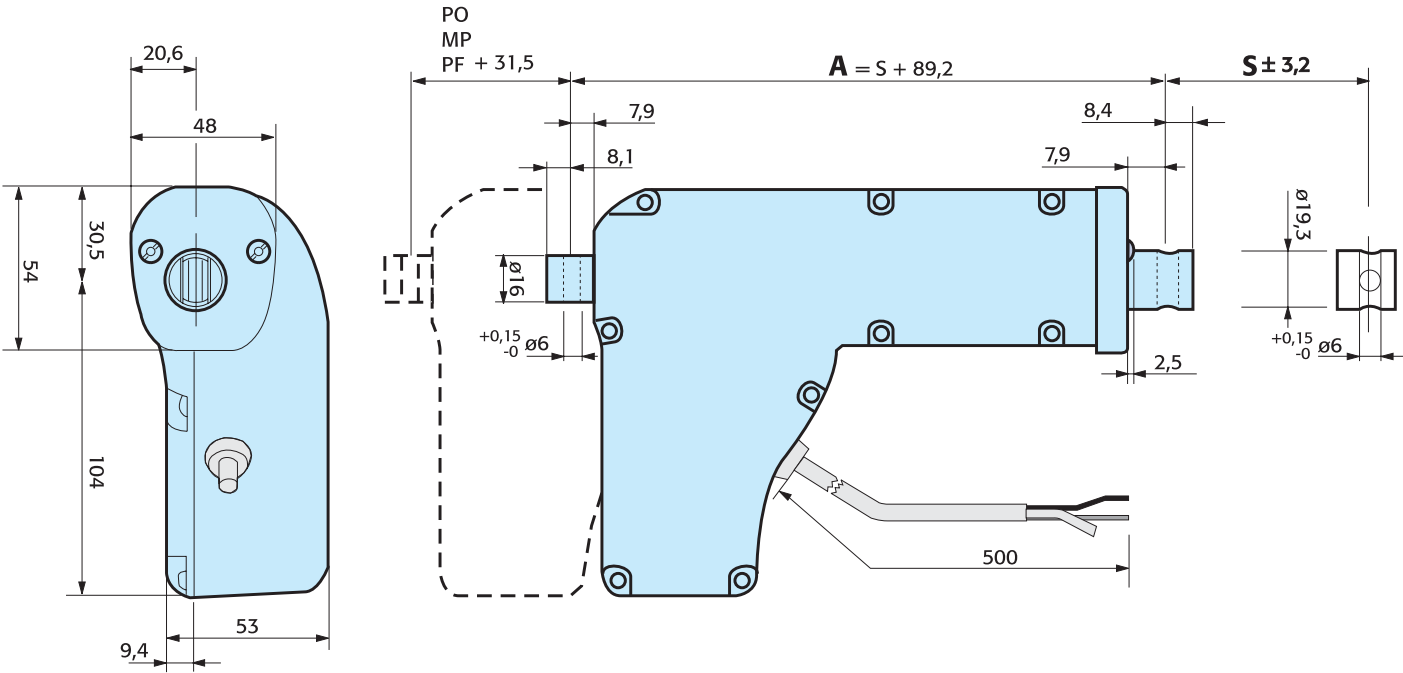

## Performance diagrams

DE •••• 17W41

DE •••• 17W42

DE •••• 17W44

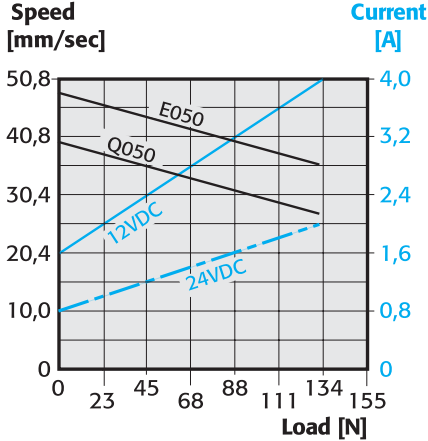
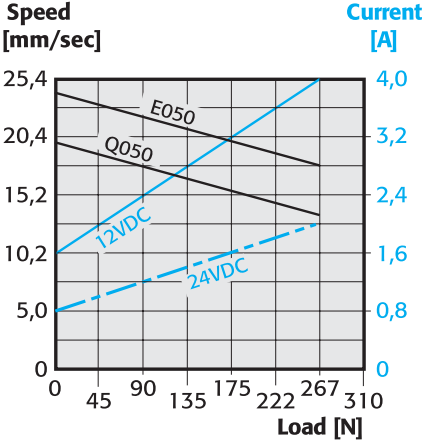
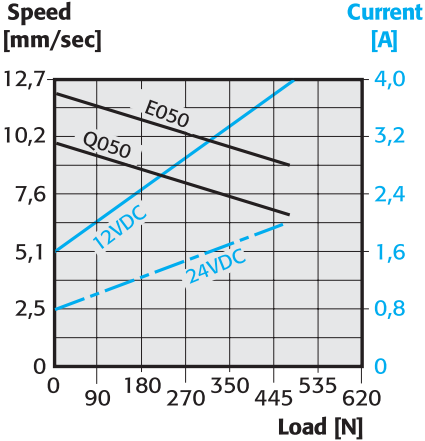

## Technical data

	
Available input voltages [Vdc]	12, 24 or 36
Screw type	Worm
Max. static load at fully retracted [N]	
DF ••• 10W51	4000
DF ••• 10W52	2000
DF ••• 10W54	1000
Min. / max. standard stroke [mm]	100 / 400
Duty cycle @ 20° C [%]	25
Temperature limits at operation [°C]	- 30 to + 65
Protection degree	IP56
Max. end play [mm]	
DF ••• 10W51	0,5
DF ••• 10W52	0,5
DF ••• 10W54	1,2
Stall current [A]	
DF12	50
DF24	25
DF36	17
Restraining torque [Nm]	–
Wire cross section [mm <sup>2</sup> ]	1,5
Wire length [mm]	1000
Connector included	on request

## Features

- Lightweight, flexible and durable
- Motor with auto reset thermal overload protection
- Anti rotation mechanism
- Estimated life is min. 40 000 cycles
- Vent tube
- Can operate in a large temperature range
- Speed up to 70 mm/s
- IP56
- Accepts large input voltage variations
- Maintenance free

## Options

- Adjustable end of stroke limit switches
- Potentiometer feedback

## Engineering notes

- No clutch

## Performance table

Model	Max. dynamic load [N]	Speed @ min. load [mm/s]	Speed @ max. load [mm/s]
DF12–10W51	2000	19	13
DF24–10W51	2000	19	13
DF36–10W51	2000	19	13
DF12– 10W52	1000	35	25
DF24–10W52	1000	35	25
DF36–10W52	1000	35	25
DF12–10W54	500	71	51
DF24–10W54	500	71	51
DF36–10W54	500	71	51

## Standard strokes

Ordering stroke [cm]	Actual stroke S [mm]
10	100
15	150
20	200
25	250
30	300
35	350
40	400

## Dimensions

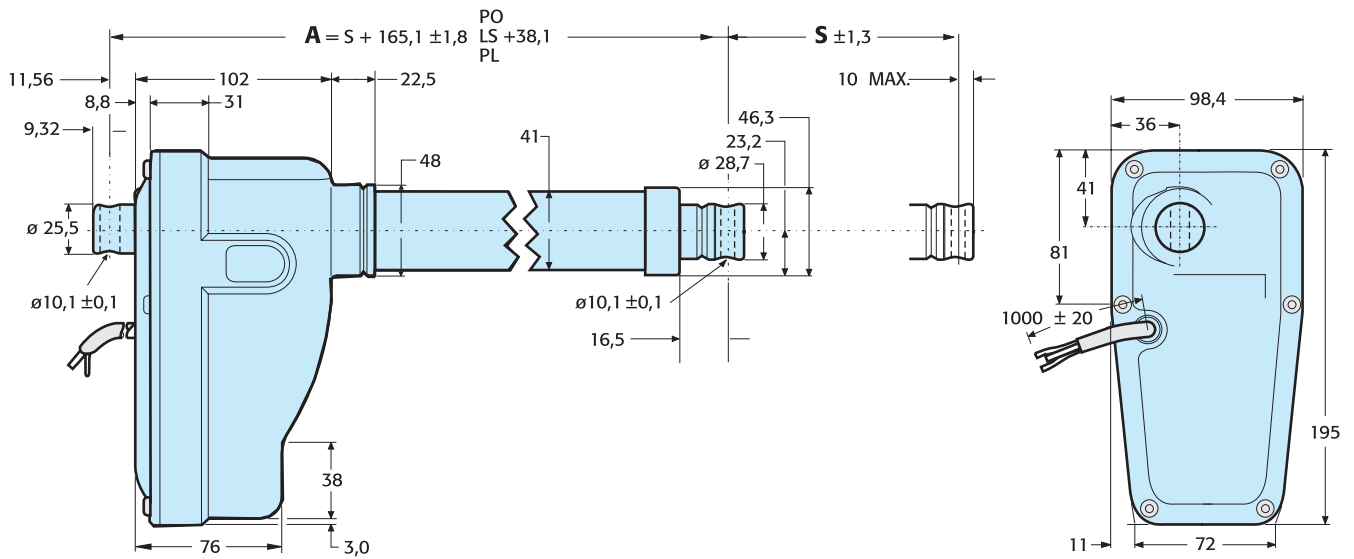

## Performance diagrams

DF •••• 10W51

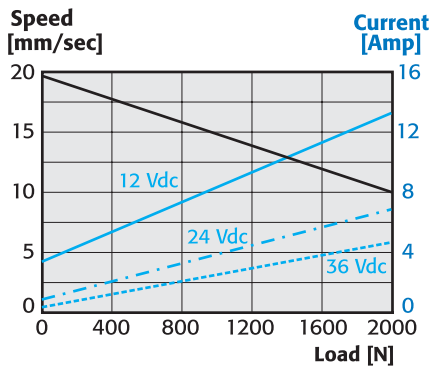

DF •••• 10W52

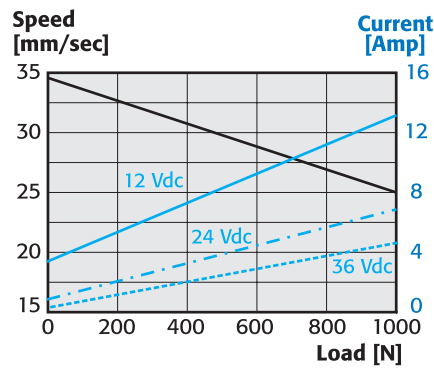

DF •••• 10W54

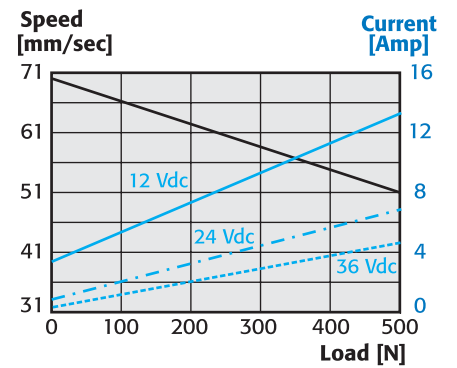



## Electrak E050, Q050

Designation example	DE12-	17	W44	M	05	PO
<b>Actuator type and supply voltage</b> E050, 12 Vdc E050, 24 Vdc E050, 36 Vdc Q050, 12 Vdc Q050, 24 Vdc Q050, 36 Vdc	DE12- DE24- DE36- DE12Q DE24Q DE36Q					
<b>Gear ratio</b> 17:1		17				
<b>Screw type / screw diameter / screw lead</b> Worm screw / 10 mm / 1,9 mm Worm screw / 10 mm / 3,8 mm Worm screw / 10 mm / 7,8 mm			W41 W42 W44			
<b>Engineering unit</b> Metric with black housing (standard for E050) Metric with white housing (standard for Q050)				M W		
<b>Stroke</b> 25 mm 50 mm 75 mm 100 mm 125 mm 150 mm 175 mm 200 mm (not possible with PO, PF or MP options).					02 05 07 10 12 15 17 20	
<b>Option</b> End off stroke limit switches Potentiometer feedback (not possible with 200 mm stroke). Potentiometer feedback + end off stroke limit switches (not possible with 200 mm stroke). Clevis at 90° + end off stroke limit switches Clevis at 90° + potentiometer feedback (not possible with 200 mm stroke).						FS PO PF MF MP

## Electrak E150

Designation example	DF12	-	10	W52	M	25	PL
<b>Actuator type and supply voltage</b> E150, 12 Vdc E150, 24 Vdc E150, 36 Vdc	DF12 DF24 DF36						
<b>Hyphen</b>		-					
<b>Gear ratio</b> 10:1			10				
<b>Screw type / screw diameter / screw lead</b> Worm screw / 14 mm / 2,9 mm Worm screw / 14 mm / 5,8 mm Worm screw / 14 mm / 12,2 mm				W51 W52 W54			
<b>Engineering unit</b> Metric					M		
<b>Stroke</b> 100 mm 150 mm 200 mm 250 mm 300 mm 350 mm 400 mm						10 15 20 25 30 35 40	
<b>Option</b> Adjustable end off stroke limit switches Potentiometer feedback Potentiometer feedback + adjustable end off stroke limit switches Clevis at 90° Clevis at 90° + adjustable end off stroke limit switches Clevis at 90° + potentiometer feedback							LS PO PL M3 ML MP

---

– Page intentionally left blank –

## Movoact



Height adjustment of work places.

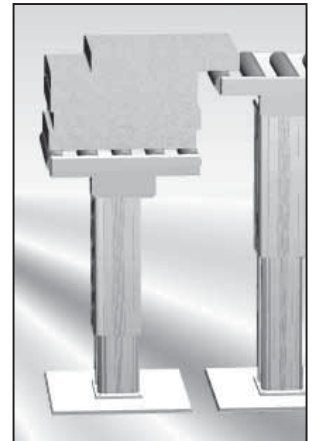

Height adjustment of loading and unloading stations.

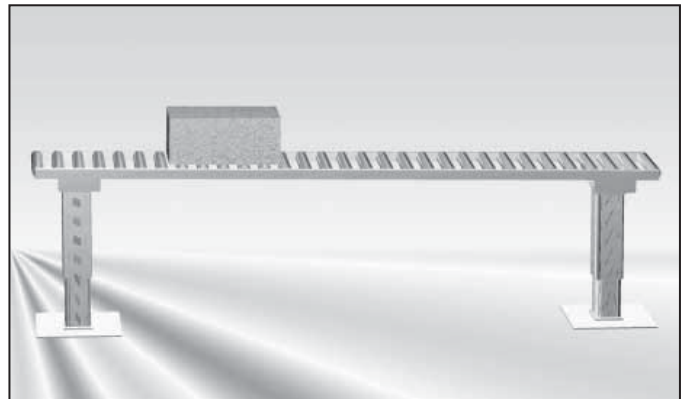

Height adjustment of conveyor systems.

- Self supporting lifting column
- Models for or AC or DC supply voltages
- Strong, rugged and reliable
- Extruded aluminium housing
- T-slots along the outer profile
- Ball screw or acme screw
- 12, 24 and 36 Vdc or 1 x 230 and 3 x 400 Vac power supply
- Stroke up to 600 mm
- Speed from 12 to 60 mm/s
- Load up to 6800 N
- High off center load capacity
- Maintenance free
- Options: potentiometer feedback, controls.

## Technical data

	
Available input voltages [Vdc]	12, 24 or 36
Available screw types	Acme or Ball
Max. static load at fully retracted [N]	
Acme screw models	11 350
Ball screw models	18 000
Min. / max. standard stroke [inch]	4 / 24
Duty cycle @ 25° C [%]	25
Temperature limits at operation [°C]	- 25 to + 65
Max. end play [mm]	1
Wire cross section [mm <sup>2</sup> ]	2,5
Wire length [mm]	2000
Connector included	no

## Features

- Rugged and robust
- Overload clutch (set to 1,2 – 1,5 x max. permissible load)
- Motor with auto reset thermal overload protection
- Accepts off center loads up to 700 Nm
- Acme or ball screw drive
- Holding brake prevents back driving on ball screw models
- Acme screw models are self-locking
- Safety nut on all ball screw models
- Can operate in a large temperature range
- Accepts large input voltage variations
- Maintenance free

## Options

- Potentiometer feedback

## Performance table

Model	Max. dynamic load [N]	Speed @ min. load [mm/s]	Speed @ max. load [mm/s]
DMD12-05A5	1100	54	32
DMD24-05A5	1100	54	32
DMD12-05B5	2250	61	37
DMD24-05B5	2250	61	37
DMD12-10A5	2250	30	18
DMD24-10A5	2250	30	18
DMD12-10B5	4500	30	19
DMD24-10B5	4500	30	19
DMD12-20A5	2250	15	12
DMD24-20A5	2250	15	12
DMD12-20B5	4500	15	12
DMD24-20B5	4500	15	12
DMD12-21B5	6800	15	11
DMD24-21B5	6800	15	11

## Standard strokes

Ordering stroke [inch]	Actual stroke S [mm]
4	102
6	152
8	203
10	254
12	305
14	356
16	406
18	457
20	508
24	610

Dimensions

Ball screw driven models

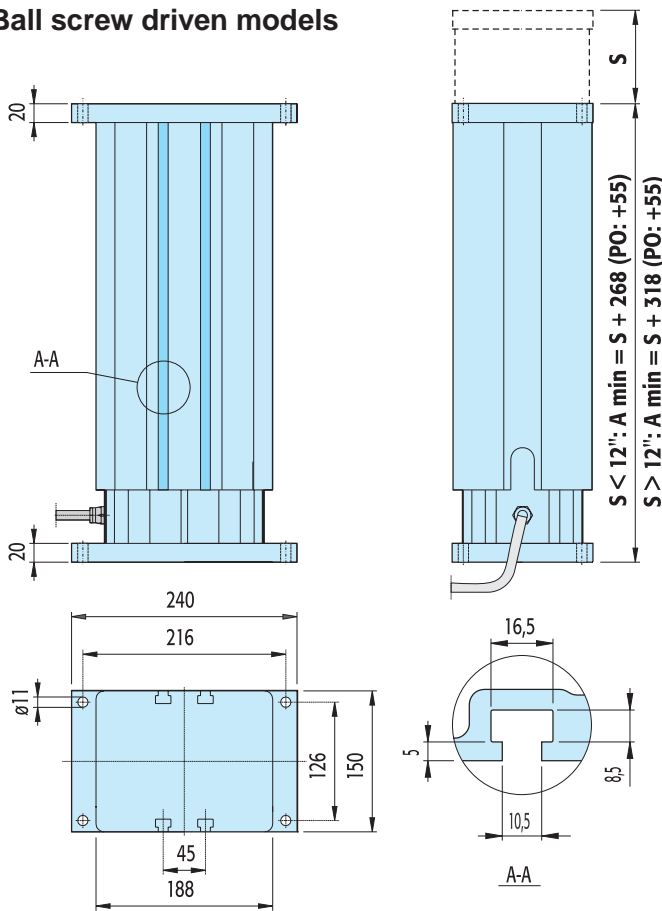

Acme screw driven models

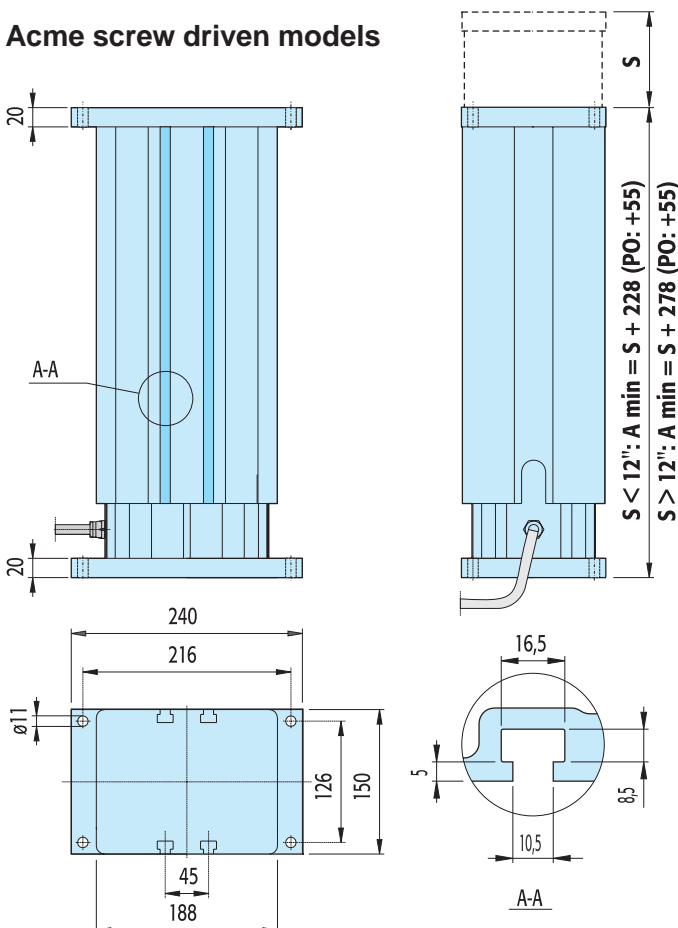

Performance diagrams

Speed and current

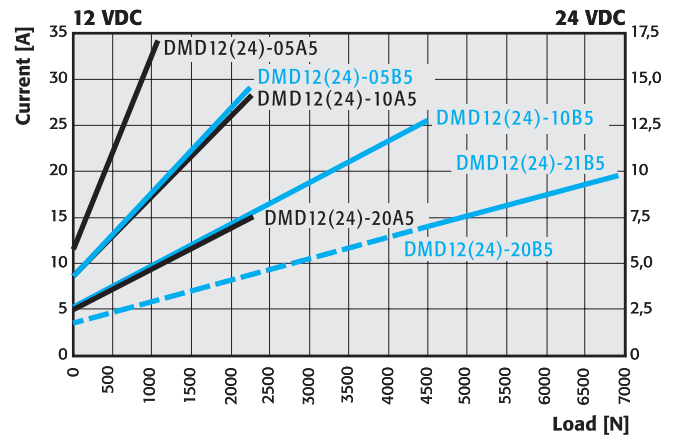
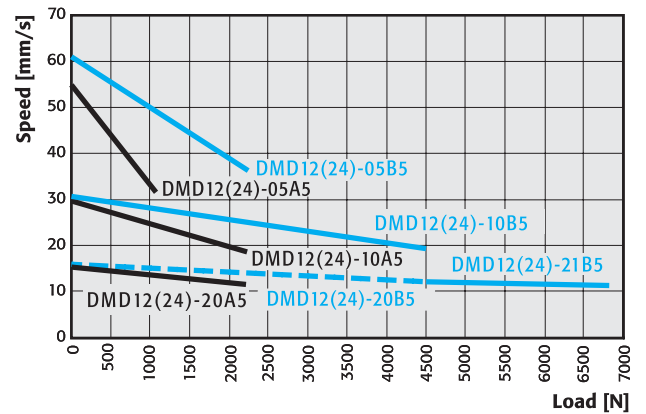

Off center load capacity

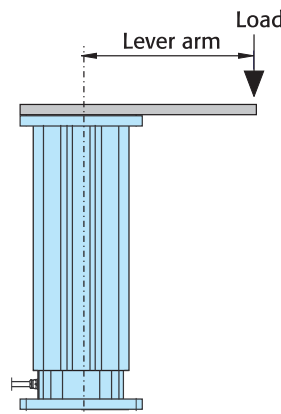
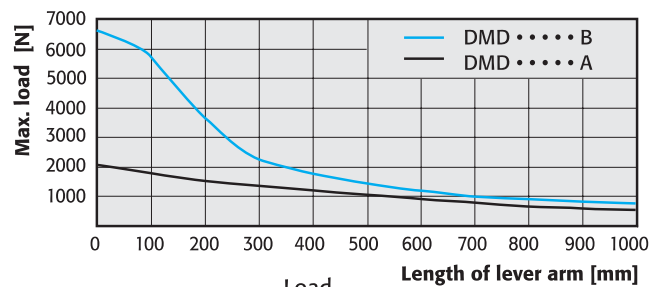

## Technical data

	
Available input voltages [Vac]	1 x 230 or 3 x 400
Input frequency [Hz]	50
Available screw types	Acme or Ball
Max. static load at fully retracted [N]	
Acme screw models	11 350
Ball screw models	18 000
Min. / max. standard stroke [inch]	4 / 24
Duty cycle @ 25° C [%]	25
Max. operation time [s]	45
Temperature limits at operation [°C]	- 25 to + 65
Max. end play [mm]	1
Wire cross section [mm <sup>2</sup> ]	2,5
Wire length [mm]	2000
Connector included	no

## Features

- Rugged and robust
- Overload clutch (set to 1,2 – 1,5 x max. permissible load)
- Motor with auto reset thermal overload protection
- Accepts off center loads up to 700 Nm
- Acme or ball screw drive
- Holding brake prevents back driving on ball screw models
- Acme screw models are self-locking
- Safety nut on all ball screw models
- Can operate in a large temperature range
- Accepts large input voltage variations
- Maintenance free

## Options

- Potentiometer feedback

## Performance table

Model	Max. dynamic load [N]	Speed @ min. load [mm/s]	Speed @ max. load [mm/s]
DMA22-05A5	1100	48	38
DMA22-05B5	2250	61	37
DMA42-05B5	2250	61	37
DMA22-10A5	2250	30	18
DMA42-10A5	2250	30	18
DMA22-10B5	4500	30	19
DMA42-10B5	4500	30	19
DMA22-20A5	2250	15	12
DMA42-20A5	2250	15	12
DMA22-20B5	4500	15	12
DMA42-20B5	4500	15	12
DMA22-21B5	6800	15	11
DMA42-21B5	6800	15	11

## Standard strokes

Ordering stroke [inch]	Actual stroke S [mm]
4	102
6	152
8	203
10	254
12	305
14	356
16	406
18	457
20	508
24	610





## Movoact-DC and Movoact-AC

Designation example	DMD12-	05B5	-	14	PO
<b>Actuator type and supply voltage</b> Movoact, 12 Vdc Movoact, 24 Vdc Movoact, 36 Vdc Movoact, 1 × 230 Vac Movoact, 3 × 400 Vac (not possible with gear ratio 5:1)	DMD12- DMD24- DMD36- DMA22- DMA42-				
<b>Gear ratio / screw type / screw diameter / screw lead</b> 5:1 / acme screw / 15,88 mm / 5,08 mm (not possible with 3 × 400 Vac motor) 10:1 / acme screw / 15,88 mm / 5,08 mm 20:1 / acme screw / 15,88 mm / 5,08 mm 5:1 / ball screw / 15,88 mm / 5,08 mm 10:1 / ball screw / 15,88 mm / 5,08 mm 20:1 / ball screw / 15,88 mm / 5,08 mm 20:1 / ball screw / 15,88 mm / 5,08 mm with hardened gear		05A5 10A5 20A5 05B5 10B5 20B5 21B5			
<b>Engineering unit</b> Inch			-		
<b>Stroke</b> 4 inch (102 mm) 6 inch (152 mm) 8 inch (203 mm) 10 inch (254 mm) 12 inch (305 mm) 14 inch (356 mm) 16 inch (406 mm) 18 inch (457 mm) 20 inch (508 mm) 24 inch (610 mm)				04 06 08 10 12 14 16 18 20 24	
<b>Option</b> No option - leave position blank Potentiometer feedback					PO

## Accessories

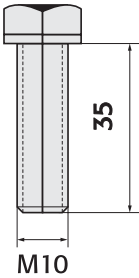
T-slot bolt (bolt and washer)	
Movoact	
M10 T-slot bolt	D800 041

## LoadMaster 80



- Rodless actuator
- Two versions, for horizontal or vertical operation
- Rigid self supporting aluminium profile
- Quiet operation for indoor domestic or medical use
- Trapezoidal or ball screw drive
- Spring loaded soft stop at end of stroke
- Stroke up to 1500 mm (longer possible upon request)
- Speed up to 110 mm/s
- Load up to 2000 N
- Options such as hand wind, spline safety function and alternative motor positions.

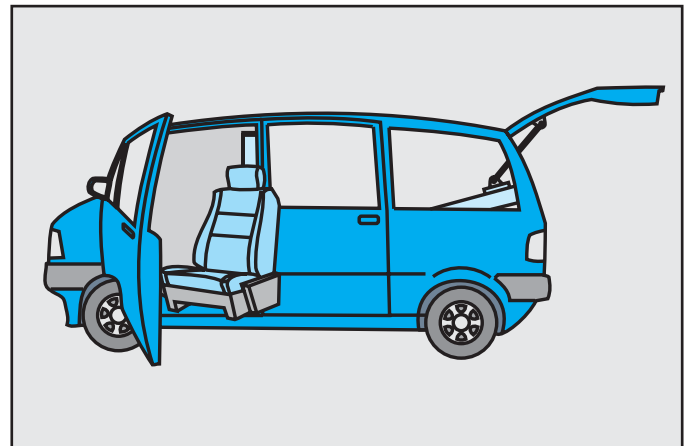

Handicap adaptation of vehicles

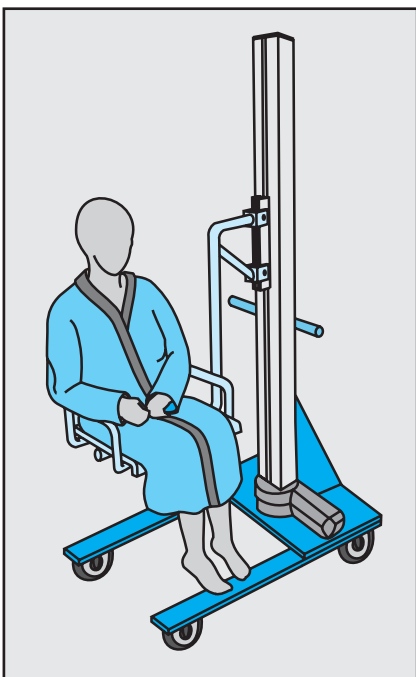

Lifting aids for disabled

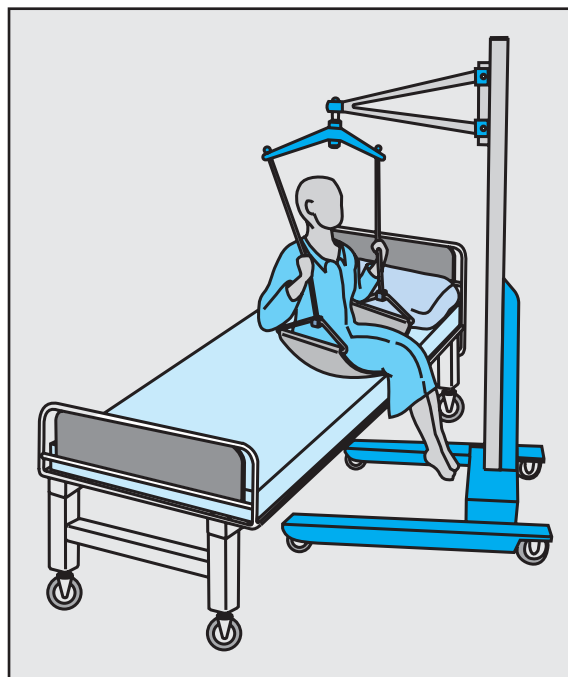

Patient lifts

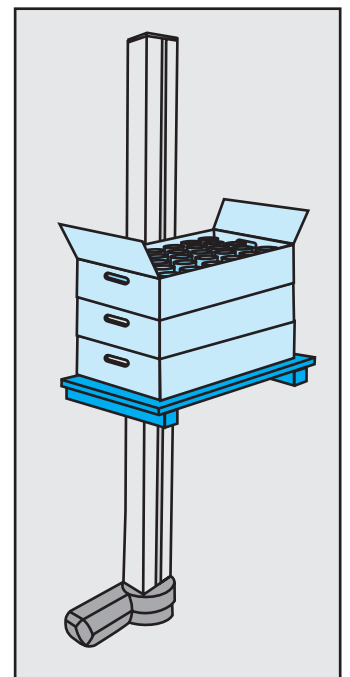

Loading and unloading stations

# LoadMaster 80 – version for vertical operation

## Technical data

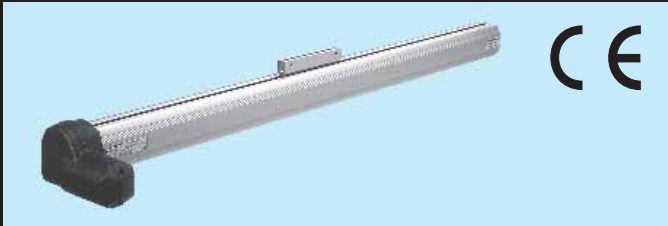
	
Available input voltages [Vdc]	12, 24
Available screw types	Trapezoidal or Ball
Max. load $F_a$ [N]	
DT •• – T68M ••••• V(F)	650
DT •• – B61M ••••• V(F)	1000
DT •• – B62M ••••• V(F)	450
DT •• – B65M ••••• V(F)	2000
Max. load torque $M_a$ [Nm]	
DT •• – T68M ••••• V(F)	250
DT •• – B61M ••~••• V(F)	400
DT •• – B62M ••~••• V(F)	180
DT •• – B65M ••~••• V(F)	750
Min. / max. standard stroke [mm]	500 / 1500
Duty cycle @ 20° C [%]	15
Max. operation time [s]	120
Temperature limits at operation [°C]	-0 to + 40
Protection degree	
With motor enclosure	IP44
Without motor enclosure	IP33
Weight [kg]	$L \times 5,7 + 2,8$
Wire cross section [mm <sup>2</sup> ]	1,5
Cable length [mm]	
Models with motor enclosure	2000
Models without motor enclosure	cable clips on motor
Connector included	
Models with motor enclosure	yes
Models without motor enclosure	no

## Performance table

Model	Maximum load $F_a$ [N]	Speed @ min. load [mm/s]	Speed @ max. load [mm/s]
DT12–T68M ••••• V(F)	650	44	29
DT24–T68M ••~••• V(F)	650	44	35
DT12–B61M ••~••• V(F)	1000	55	37
DT24–B61M ••~••• V(F)	1000	55	43
DT12–B62M ••~••• V(F)	450	110	67
DT24–B62M ••~••• V(F)	450	110	83
DT12–B65M ••~••• V(F)	2000	28	19
DT24–B65M ••~••• V(F)	2000	28	22

## Features

- Rodless actuator for vertical operation
- Durable, corrosion free and lightweight
- Stable self supporting extruded aluminium profile
- Easy T-slot mounting
- Trapezoidal or ball screw drive
- Holds load at stand still (self locking)
- Spring loaded soft stop at end of stroke
- Safety nut on all ball screw models
- Motor with auto reset thermal overload protection
- Can operate in a large temperature range
- Accepts large input voltage variations
- IP44 (enclosed version) or IP33
- Maintenance free

## Options

- Hand wind
- Alternative motor position
- Spline safety function

## Forces

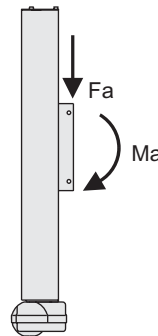

## Motor positions

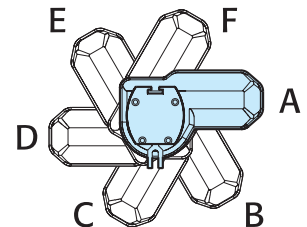

## Standard strokes

Ordering stroke [cm]	Actual stroke S [mm]
50	500
60	600
70	700
80	800
90	900
100	1000
110	1100
120	1200
130	1300
140	1400
150	1500

## T-slot bolt kit

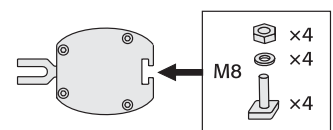

P/n D680 507

# LoadMaster 80 – version for vertical operation

## Dimensions

### Vertical models

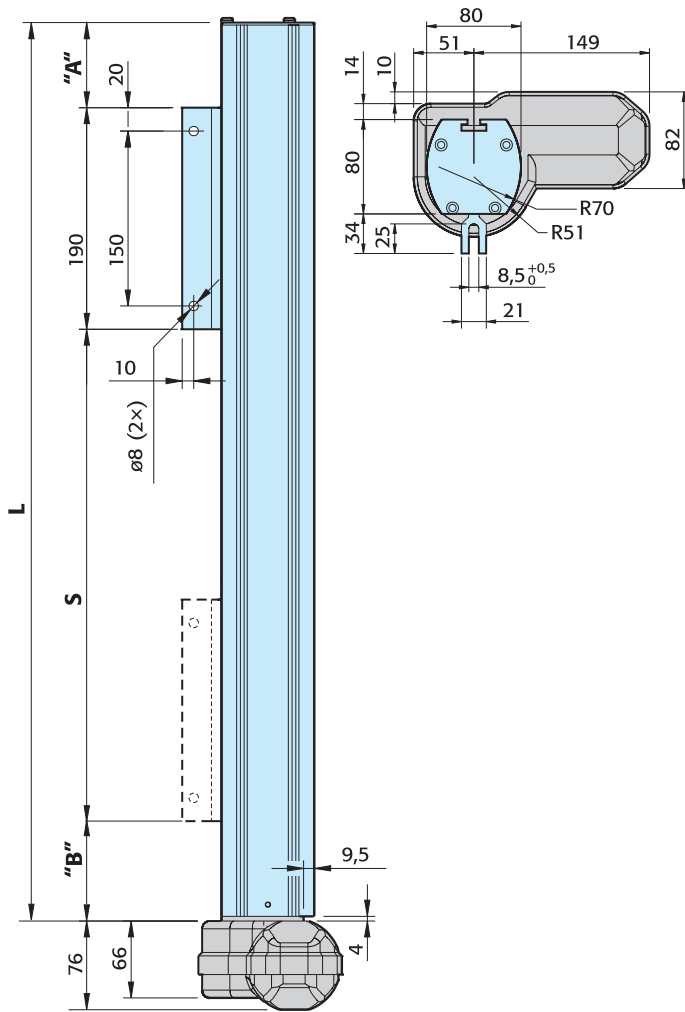

Model	"A"	"B"
DT •• – B65M ••••• V •	53	97
DT •• – B62M ••••• V •	53	120
DT •• – B61M ••••• V •	53	120
DT •• – T68M ••••• V •	50	71

Model	"A"	"B"
DT •• – B65M ••••• F •	53	126
DT •• – B62M ••••• F •	53	144
DT •• – B61M ••••• F •	53	144
DT •• – T68M ••••• F •	50	90

## Performance diagrams

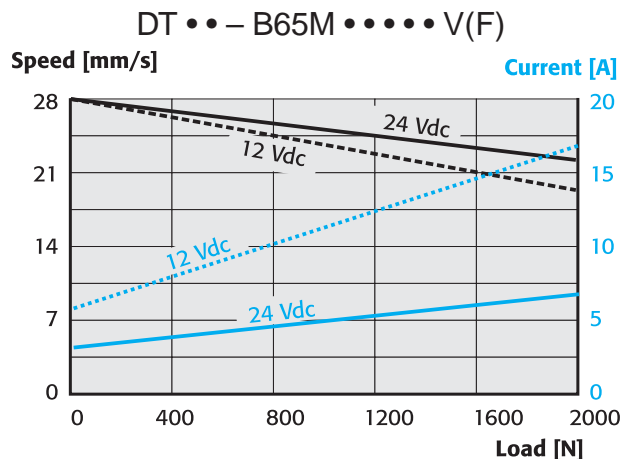
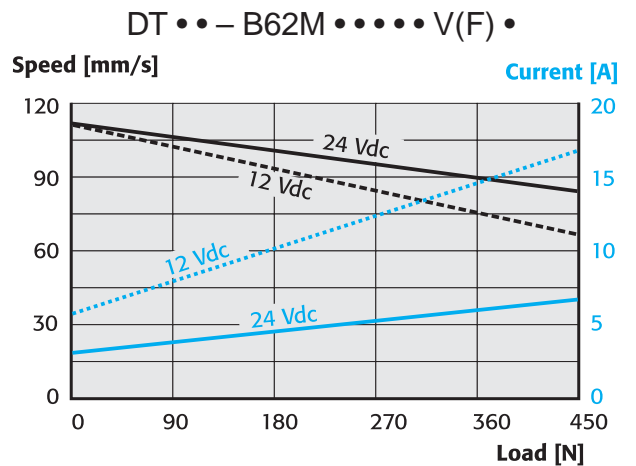
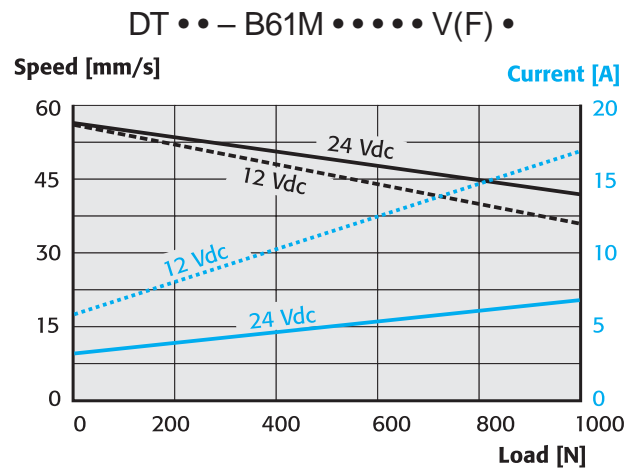
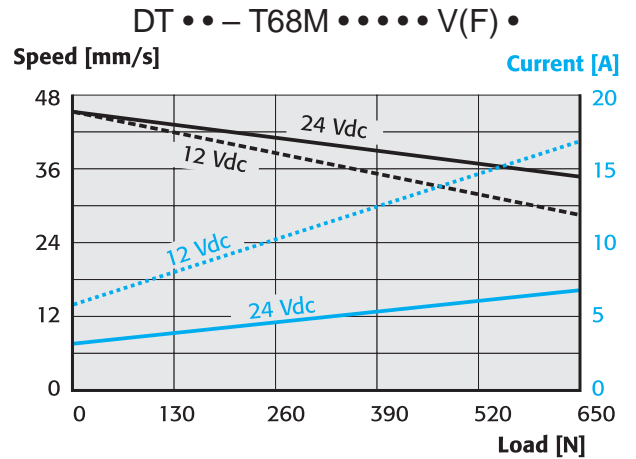

# LoadMaster 80 – version for horizontal operation

## Technical data

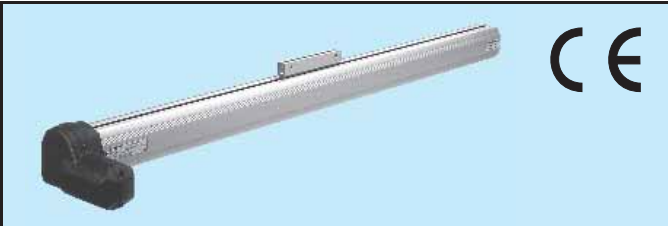
	
Available input voltages [Vdc]	12, 24
Available screw types	Trapezoidal or Ball
Max. load Fb [N]	2000
Max. load torque Mb [Nm]	
DT ••– T68M ••••• H	250
DT ••– B61M ••••• H	400
DT ••– B62M ••••• H	180
DT ••– B65M ••••• H	750
Min. / max. standard stroke [mm]	500 / 1500
Duty cycle @ 20° C [%]	15
Max. operation time [s]	120
Temperature limits at operation [°C]	-0 to + 40
Protection degree	
With motor enclosure	IP44
Without motor enclosure	IP33
Weight [kg]	L x 5,7 + 2,8
Wire cross section [mm <sup>2</sup> ]	1,5
Cable length [mm]	
Models with motor enclosure	2000
Models without motor enclosure	cable clips on motor
Connector included	
Models with motor enclosure	yes
Models without motor enclosure	no

## Features

- Rodless actuator for horizontal operation
- Durable, corrosion free and lightweight
- Stable self supporting extruded aluminium profile
- Easy T-slot mounting
- Trapezoidal or ball screw drive
- Spring loaded soft stop at end of stroke
- Safety nut on all ball screw models
- Motor with auto reset thermal overload protection
- Can operate in a large temperature range
- Accepts large input voltage variations
- IP44 (enclosed version) or IP33
- Maintenance free

## Options

- Hand wind
- Alternative motor position

## Forces

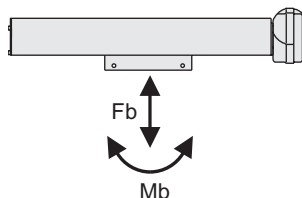

## Motor positions

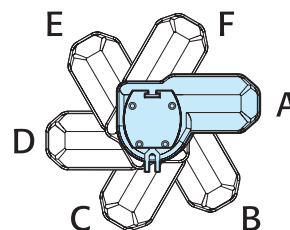

## Performance table

Model	Maximum load Fb [N]	Speed @ min. load [mm/s]	Speed @ max. load [mm/s]
DT12–T68M ••••• H	2000	44	37
DT24–T68M ••••• H	2000	44	37
DT12–B61M ••••• H	2000	55	50
DT24–B61M ••••• H	2000	55	50
DT12–B62M ••••• H	2000	110	73
DT24–B62M ••••• H	2000	110	87
DT12–B65M ••••• H	2000	28	28
DT24–B65M ••••• H	2000	28	28

## Standard strokes

Ordering stroke [cm]	Actual stroke S [mm]
50	500
60	600
70	700
80	800
90	900
100	1000
110	1100
120	1200
130	1300
140	1400
150	1500

## T-slot bolt kit

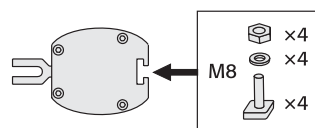

P/n D680 507

# LoadMaster 80 – version for horizontal operation

## Dimensions

### Horizontal models

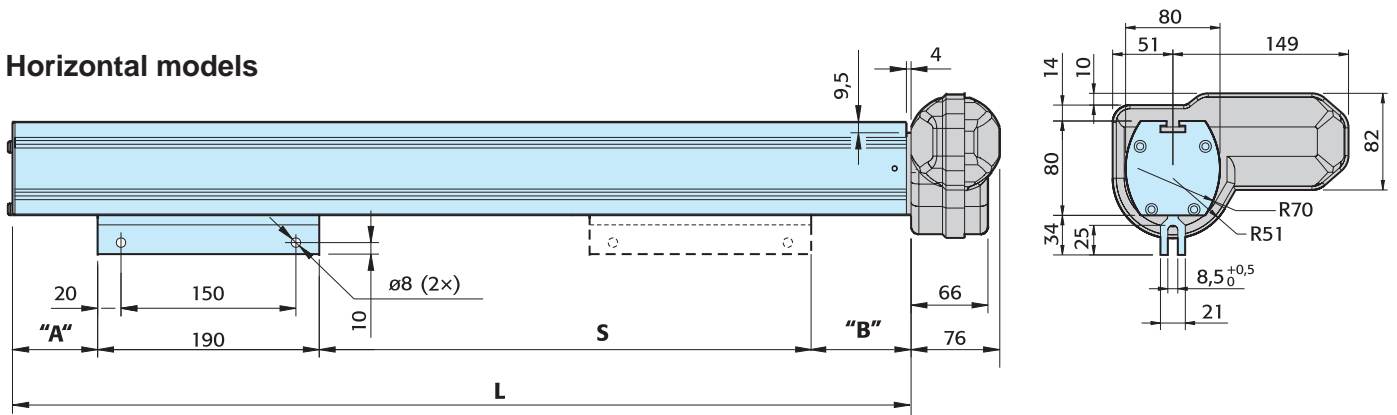

### Deflection of profile

Model	"A"	"B"
DT •• – B65M ••••• H •	79,0	77,0
DT •• – B62M ••••• H •	102,0	77,0
DT •• – B61M ••••• H •	102,0	77,0
DT •• – T68M ••••• H •	54,0	77,0

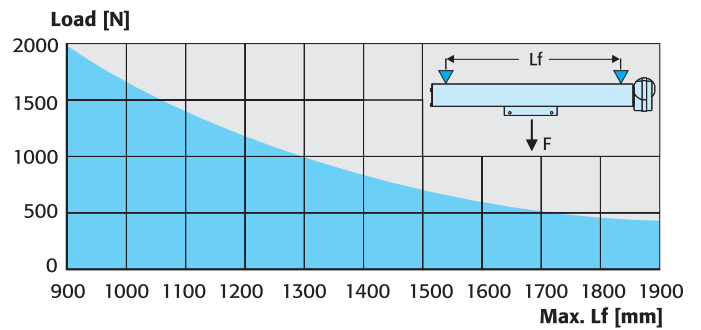

## Performance diagrams

### DT •• – T68M ••••• H •

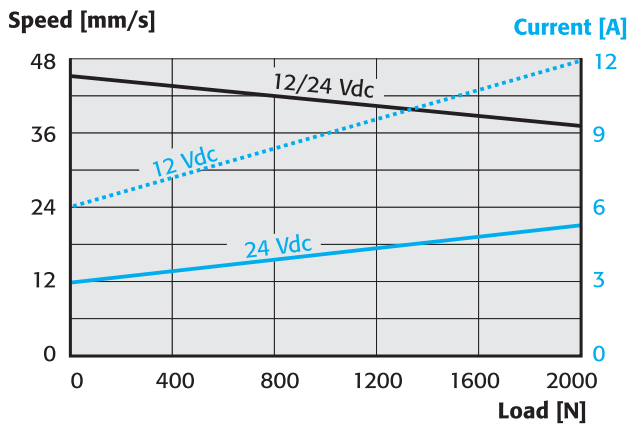

### DT •• – B61M ••••• H •

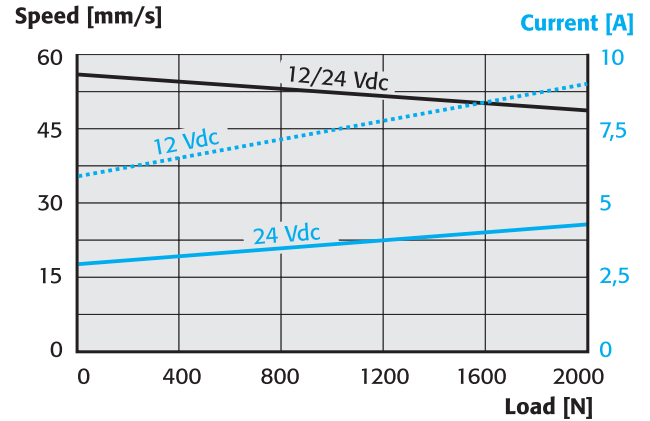

### DT •• – B62M ••••• H •

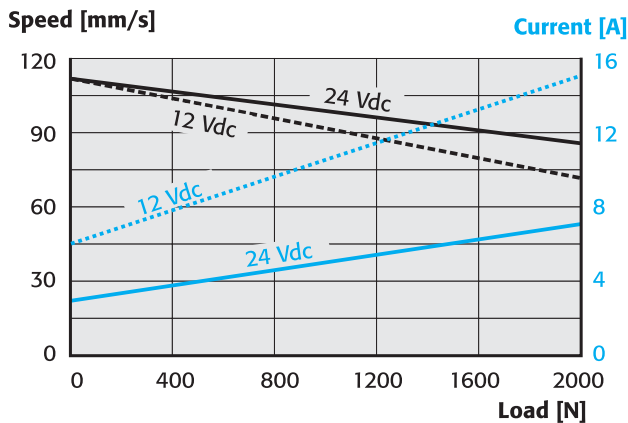

### DT •• – B65M ••••• H •

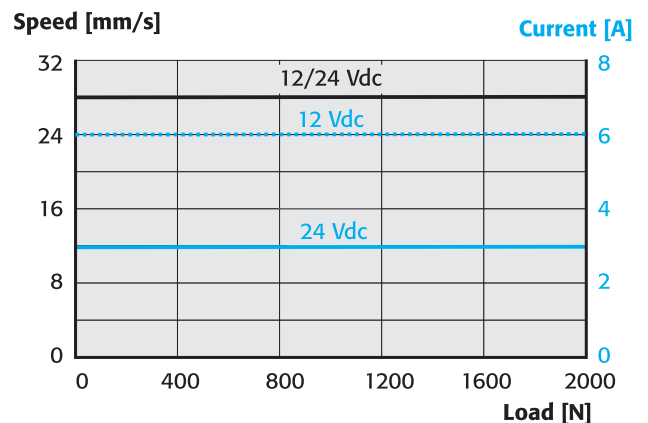

## LoadMaster 80

Designation example	D	T	12	-	B61	M	080	A	C	V	X
<b>Motor type</b> Dc motor	D										
<b>Actuator type</b> LoadMaster 80		T									
<b>Supply voltage</b> 12 Vdc 24 Vdc			12 24								
<b>Hyphen</b>				-							
<b>Screw type / diameter / lead</b> Trapezoidal / 16 mm / 8 mm Ball screw / 16 mm / 10 mm Ball screw / 16 mm / 20 mm Ball screw / 15,88 mm / 5,08 mm					T68 B61 B62 B65						
<b>Engineering unit</b> Millimeter						M					
<b>Stroke</b> 50 cm 60 cm 70 cm 80 cm 90 cm 100 cm 110 cm 120 cm 130 cm 140 cm 150 cm							050 060 070 080 090 100 110 120 130 140 150				
<b>Motor position</b> 0° 60° 120° 180° 240° 300°								A B C D E F			
<b>Motor enclosure</b> With enclosure Without enclosure									C U		
<b>Mounting position</b> Vertical with motor down Vertical with motor down + spline safety function Horizontal										V F H	
<b>Options</b> No option Handwind											X H





- Controls available for all actuator models
- Models for AC or DC power supply
- Versions with limit switch inputs
- Versions with electronic limit switches (ELS)
- Models with outputs for one or two actuators
- Hand controls available for most models

AC-020  
AC-050  
AC-150

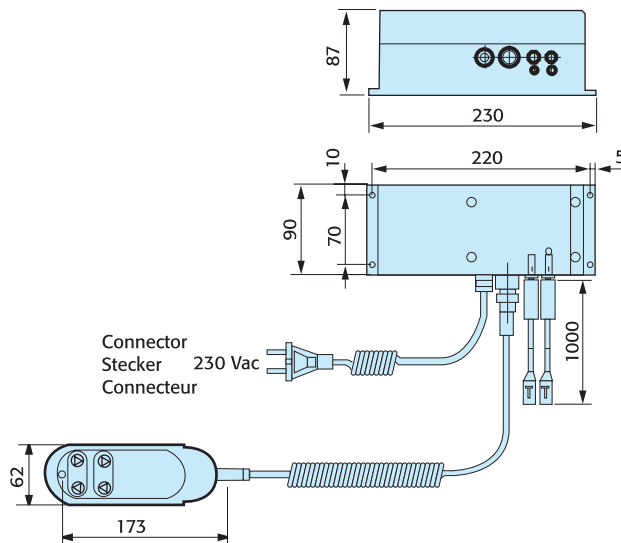

Control model	AC-020		AC-050		AC-150	
Part number	DCB24-1S3	DCB24-2S33	DCE24-1E	DCE24-2E	DCF24-1F	DCF24-2F
Suitable actuator	LA1	LA1	E050 Q050	E050 Q050	E150 LoadMaster 80	E150 LoadMaster 80
Input voltage [Vac]	1 × 230	1 × 230	1 × 230	1 × 230	1 × 230	1 × 230
Input frequency [Hz]	50	50	50	50	50	50
Output voltage [Vdc]	24	24	24	24	24	24
Number of outputs	1	2*	1	2*	1	2*
Max. output current [A]	3	3	2,5	2,5	8	8
Duty cycle @ 20° C [%]	10	10	10	10	10	10
Electronic limit switches	yes	yes	yes	yes	yes	yes
Limit switch inputs	no	no	no	no	no	no
Hand control	included	included	included	included	included	included

\* Both outputs share the max. output current, i.e if the max. output current is 3A then total current can not exceed 3A if using one or two outputs.

AC-247 ELS

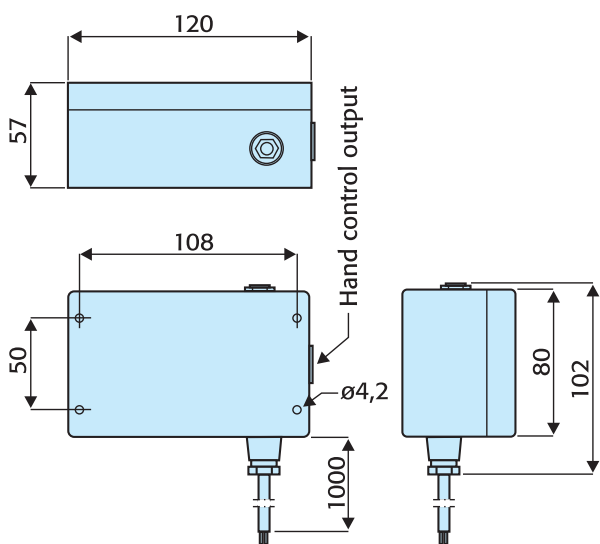

Control model	AC-247 ELS		
Part number	D604 110	D604 111	D604 112
Suitable actuator	E050, Q050, E150, LA1 LoadMaster 80	E050, Q050, E150, LA1 LoadMaster 80	E050, Q050, E150, LA1 LoadMaster 80
Input voltage [Vdc]	12 or 24	12	24
Output voltage [Vdc]	12 or 24	12	24
Number of outputs	1	1	1
Max. output current @ 12 Vdc [A]	10	12	–
@ 24 Vdc [A]	5	–	8
Duty cycle @ 20°C [%]	10	10	10
Electronic limit switches	yes	yes	yes
Limit switch inputs	no	no	no
Suitable hand control	DCB14-1H	D603 888	D603 888

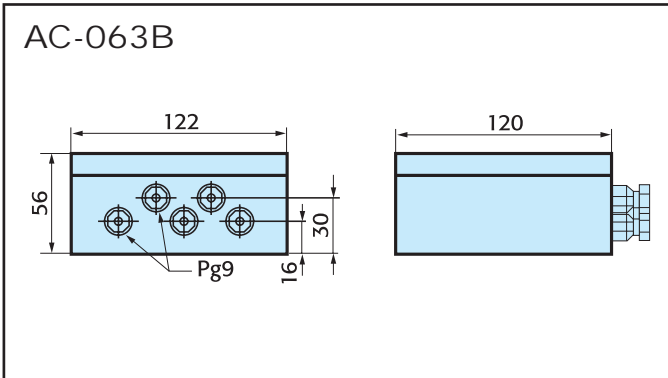

Control model	AC-063B	
Part number	DC24-1B	DCA24-1B
Suitable actuator	LA10 PPA-DC Movoact	LA14
Input voltage [Vdc]	12 - 36	12 - 36
Output voltage [Vdc]	12 - 36	12 - 36
Number of outputs	1	1
Max. output current		
@ 12 Vdc [A]	30	30
@ 24 Vdc [A]	17	17
@ 36 Vdc [A]	12	12
Duty cycle @ 20° C [%]	10	10
Electronic limit switches	no	no
Limit switch inputs	no	yes*
Hand control*	not included	not included

\*Suitable handcontrol DCB14-1H

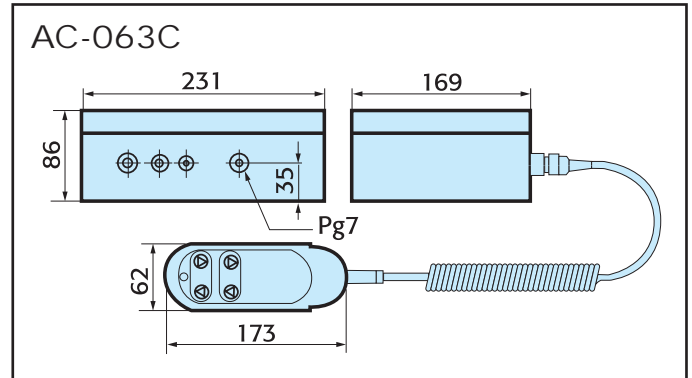

Control model	AC-063C	
Part number	DC24-1C	DCA24-1C
Suitable actuator	LA10 PPA-DC Movoact	LA14
Input voltage [Vac]	1 × 230	1 × 230
Input frequency [Hz]	50	50
Output voltage [Vdc]	24	24
Number of outputs	1	1
Max. output current [A]	17	17
Duty cycle @ 20° C [%]	10	10
Electronic limit switches	no	no
Limit switch inputs	no	yes*
Hand control	included	included

\*Limit switches or sensors must be of type normally closed.

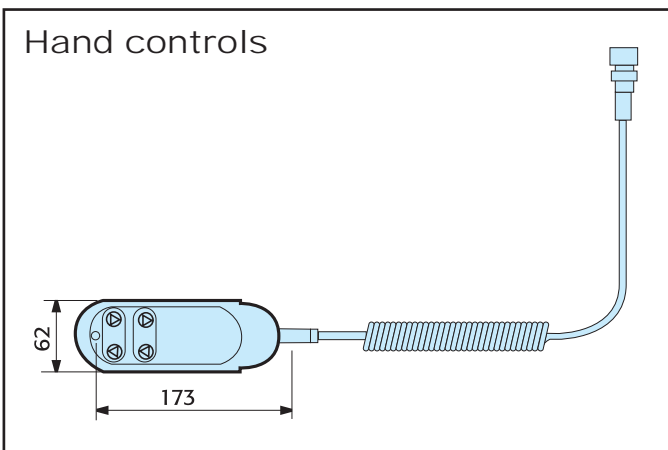

Part number	DCB14-1H	D603 888
Suitable control	D604 110	D604 111 / D604 112
Cable length [m]	850 ±50	850 ±50

---

– Page intentionally left blank –

---

– Page intentionally left blank –



DANAHER MOTION is a trademark.

Danaher Motion makes every attempt to ensure accuracy and reliability of the specifications in this publication. Specifications are subject to change without notice. Danaher Motion provides this information "AS IS" and disclaims all warranties, express or implied, including, but not limited to, implied warranties of merchantability and fitness for a particular purpose. It is the responsibility of the product user to determine the suitability of this product for a specific application.

©2005 Danaher Motion. Tollo Linear AB. Tobbe Johansson. 2005-MAY-27. dw110450gb-0521

**FOR IMMEDIATE ASSISTANCE:**

Internet: [www.LinearActuators.com](http://www.LinearActuators.com)  
Catalogue request: [catalogues@danahermotion.com](mailto:catalogues@danahermotion.com)

Great Britain  
Danaher Motion  
Fishleigh Road  
Roundswell Business Park  
Barnstaple, Devon  
EX31 3UD  
Tel. +44 (0) 1271 334500  
Fax. +44 (0) 1271 334502  
E-mail [LMSEurope@danahermotion.com](mailto:LMSEurope@danahermotion.com)

France  
Danaher Motion  
C.P. 80018  
12, Rue Antoine Becquerel - Z.I. Sud  
Bâtiment Paul Tiger 2  
F-72026 Le Mans Cedex 2  
Tel. +33 (0)2 43 50 03 30  
Fax. +33 (0)2 43 50 03 39  
E-mail [sales.france@tollo.com](mailto:sales.france@tollo.com)

Germany  
Danaher Motion GmbH  
Postfach 1153  
D-72645 Wolfschlugen  
Tel. +49 (0)180 5 24 67 90  
Fax. +49 (0)180 5 24 40 85  
E-mail [helpdesk@tollo.com](mailto:helpdesk@tollo.com)

Italy  
Danaher Motion Srl  
Via Brughetti ZI  
20030 Bovisio Masciago (MI)  
Tel. +39 (0)362 594 260  
Fax. +39 (0)362 594 263  
Email [info@danahermotion.it](mailto:info@danahermotion.it)

Scandinavia  
Danaher Motion  
Tollo Linear AB  
Box 9053  
SE-291 09 Kristianstad  
Tel. +46 (0)44 24 67 00  
Fax. +46 (0)44 24 40 85  
E-mail [helpdesk@tollo.com](mailto:helpdesk@tollo.com)

Spain  
Danaher Motion  
Tollo Linear Spain  
Badal, 29-31 7th, 1st  
08014 Barcelona  
Tel. +34 (0) 9329 80278  
Fax. +34 (0) 9329 80278  
E-mail [helpdesk@tollo.com](mailto:helpdesk@tollo.com)

USA, Canada or Mexico  
Danaher Motion  
203A West Rock Road  
Radford, VA 24141 USA  
Tel. +1-540-633-3400  
Fax. +1-540-639-4162  
E-mail [DMAC@DanaherMotion.com](mailto:DMAC@DanaherMotion.com)

Europe  
Tel. +46 (0)44 24 67 00  
Fax. +46 (0)44 24 40 85  
E-mail [helpdesk@tollo.com](mailto:helpdesk@tollo.com)

Rest of the World  
Tel. +1 (516) 888-8937  
Fax. +1 (516) 888-7109